



.....
HAWK 2LP Family:
.....

ST32430N/ND
.....

ST31230N/ND
.....

.....
Product Manual, Volume 1
.....

.....
HAWK 2LP Family:
.....

ST32430N/ND
.....

ST31230N/ND
.....

.....
Product Manual, Volume 1
.....



© 1996 Seagate Technology, Inc. All rights reserved
Publication Number: 77767471, Revision F
March 1996

Seagate®, Seagate Technology®, and the Seagate logo are registered trademarks of Seagate Technology, Inc. Hawk™, SeaFAX™, SeaFone™, SeaTDD™ and SeaBOARD™ are trademarks of Seagate Technology, Inc. Other product names are registered trademarks or trademarks of their own.

Seagate reserves the right to change, without notice, product offerings or specifications. No part of this publication may be reproduced in any form without written permission of Seagate Technology, Inc.

Revision Status Summary Sheet

Revision	Authorization	Date	Writer/Eng.	Sheets affected
A Issue		8/29/94	D. Ashby R. Metzner	v through viii, 1 through 59
B	PLD:86170	10/24/94	D. Ashby	v, 12, 13, 37 through 41
C	PLD:86221	12/15/94	D. Ashby Gordon Douglas	v, 24 and 59
D	PLD: 86577	08/30/95	D. Ashby	v and 33
E	PLD: 86717	1/24/96	D. Ashby	v, vi and 2
F	PLD: 86769			v and 18

Notice:

Product Manual 77767471 is Volume 1 of a two Volume document with the SCSI interface information in the Volume 2 SCSI Interface Product Manual, P/N 77738479.

If the SCSI Interface information is needed the Volume 2 Interface Manual should be ordered, P/N 77738479.

Table of Contents

1.0	Scope	1
2.0	Applicable standards and reference documentation	2
2.1	Standards	2
2.2	Electromagnetic Compliance for the European Unionn	2
2.3	Applicable reference documents	2
3.0	General description	3
4.0	Features	5
4.1	Performance	5
4.2	Reliability	5
4.3	Unformatted and formatted capacities	6
4.4	Options (factory installed)	6
4.5	Optional accessories (user installed)	6
4.6	Installation	7
5.0	Performance characteristics	8
5.1	Internal drive characteristics (transparent to user)	8
5.2	SCSI Drive Seek and write performance characteristics (visible to user)	8
5.2.1	Access time	8
5.2.2	Format drive command execution time	9
5.2.3	Read data command execution time	9
5.2.4	Write data command execution time	9
5.3	Generalized performance characteristics	10
5.4	Start/stop time	12
5.5	Prefetch/multi segmented cache control	12
5.5.1	Cache operation	12
5.5.2	Prefetch operation	13
5.6	Caching write data	14
6.0	Reliability specifications	15
6.1	Error rates	15
6.1.1	Read errors	15
6.1.2	Environmental interference	15
6.1.3	Write errors	16
6.1.4	Seek errors	16
6.2	Reliability and service	16
6.2.1	Mean time between failure	16
6.2.2	Preventive maintenance	16
6.2.3	Service life	16
6.2.4	Service philosophy	17
6.2.5	Installation	17
6.2.6	Service tools	17
6.2.7	Product warranty	17
7.0	Physical/electrical specifications	18
7.1	AC power requirements	18
7.2	DC power requirements	18
7.2.1	Conducted noise immunity	18
7.2.2	Power sequencing	19
7.2.3	12 V - current profile	19

7.3	Heat/power dissipation	20
7.4	Environmental limits	20
7.4.1	Temperature	20
7.4.2	Relative humidity	21
7.4.3	Effective altitude (sea level ref)	22
7.4.4	Shock and vibration	22
7.4.5	Air cleanliness	24
7.5	Electromagnetic compatibility	24
7.5.1	Electromagnetic susceptibility	24
7.6	Mechanical specifications	25
7.6.1	Drive orientation	26
7.6.2	Cooling	26
7.6.3	Drive mounting	26
8.0	Media characteristics	27
8.1	Media description	27
9.0	Defect and error management	28
9.1	Drive internal defects/errors	28
9.2	SCSI systems error considerations	28
10.0	Option/configuration headers	29
10.1	Drive ID/Option select header	29
10.2	Grounding	31
11.0	Interface requirement	32
11.1	General description	32
11.2	SCSI interface messages supported	32
11.3	SCSI interface commands supported	33
11.3.1	Inquiry data	35
11.3.2	Mode sense data	36
11.4	SCSI bus conditions and miscellaneous Features supported	41
11.5	Synchronous data transfer	42
11.5.1	Synchronous data transfer periods supported	42
11.5.2	REQ/ACK offset	42
11.6	Physical interface	42
11.6.1	DC cable and connector	44
11.6.2	Physical characteristics	44
11.6.3	Mating connector requirements	45
11.6.4	Electrical description	49
11.7	Disc drive timing	53

12.0	Options	55
12.1	Front panel	55
12.2	Single unit shipping pack	55
12.3	Installation manual	55
13.0	Accessories	56
13.1	Front panel kit	56
13.2	Additional Installation Guide copies	56
14.0	Seagate support services	57

1.0 Scope

This Manual describes the Seagate Technology, Inc. Hawk 2LP family Disc Drives. This high capacity, high performance member of the Seagate 1 inch high 3.5 inch rigid disc family is a next generation product from the ST31200 disc drive. Performance information is given in Section 5. The Hawk 2LP family model drives interface is defined for functional compatibility to be a subset of the Seagate SCSI Interface Manual 77738479, and the ANSI SCSI-2/SCSI-3 standards. The Hawk 2LP family drives are classified as “Intelligent” peripherals. The Hawk 2LP Family provides Level 2 conformance (highest level) with the ANSI SCSI-1 standard. Details of the Hawk 2LP Family drive SCSI implementation are provided in Section 11 of this Manual, (Vol. 1) and in the SCSI Interface Product Manual P/N 77738479 (Vol. 2; Ver. 2).

The Hawk 2LP family consists of ST32430N/ND and ST31230N/ND products.

From this point on in this Product Manual the reference to Hawk 2LP family models is referred to as “the drive” (unless reference to individual models are necessary).

The drive printed circuit board is referred to as a PCB.

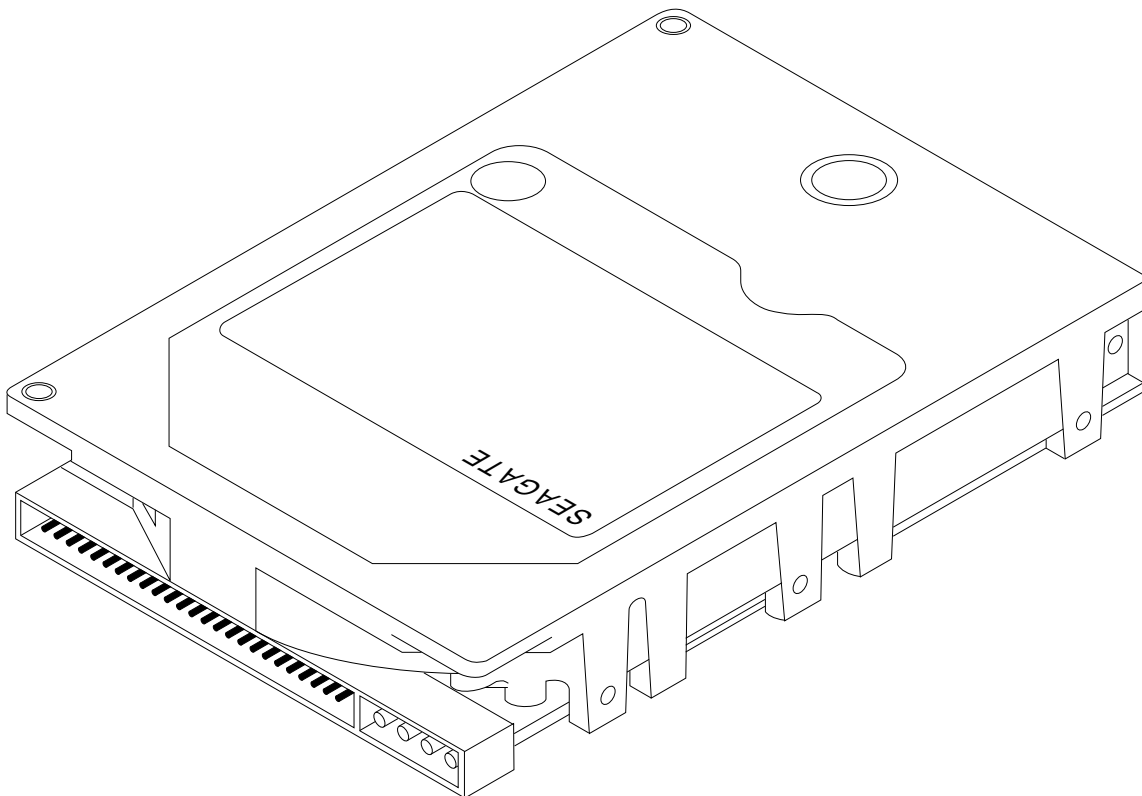

Figure 1-1. Hawk 2LP family drive

2.0 Applicable standards and reference documentation

The drive has been developed as a system peripheral to the highest standards of design and construction. The drive depends upon its host equipment to provide adequate power and environment in order to achieve optimum performance and compliance with applicable industry and governmental regulations. Special attention must be given in the areas of safety, power distribution, shielding, audible noise control, and temperature regulation. In particular, the drive must be securely mounted in order to guarantee the specified performance characteristics.

2.1 Standards

The Hawk 2LP Family complies with Seagate standards as noted in the appropriate sections of this Manual and the Seagate SCSI Interface Manual, P/N 77738479 (Vol. 2, Version 2).

The Hawk 2LP Family is a UL Recognized component per UL 1950 and a CSA Certified component per CAN/CSA-C22.2 No. 950-M89. It also meets the requirements of DIN VDE 0805:1993 and EN60950: 1992 (IEC 950).

The drive, as delivered, is designed for system integration and installation into a suitable enclosure prior to use. As such the drive is supplied as a subassembly and is not subject to Subpart J of Part 15 of the FCC Rules and Regulations nor the Radio Interference Regulations of the Canadian Department of Communications. However, the unit has been tested using proper shielding and grounding and found to be compliant with Class A limits of the FCC Rules and the Regulations of The Canadian Department of Communications.

The physical design characteristics of the drive serve to minimize radiation when installed in an enclosure that provides reasonable shielding. As such, the drive is capable of meeting the Class B limits of the FCC Rules and Regulations of the Canadian Department of Communication. However, it is the users responsibility to assure that the drive meets the appropriate EMI requirements in their system. Shielded I/O cables may be required if the enclosure does not provide adequate shielding. If the I/O cables are external to the enclosure, shielded cables should be used, with the shields grounded to the enclosure and to the host controller.

2.2 Electromagnetic Compliance for the European Union

If this model has the CE Marking it complies with the European Union requirements of the Electromagnetic Compatibility Directive 89/336/EEC of 03 May 1989 as amended by Directive 92/31/EEC of 28 April 1992 and Directive 93/68/EEC of 22 July 1993.

Seagate uses an independent laboratory to confirm compliance to the above directives. The drive was tested in a representative system for typical applications. The selected system represents the most popular characteristics for test platforms. The system configurations include:

- 486, Pentium, and Power PC Microprocessors
- 3.5-inch Floppy Disc Drive
- Keyboard
- Monitor/Display

Although the test system with this Seagate model complies to the directives, we cannot guarantee that all systems will comply. The computer manufacturer or system integrator shall confirm EMC compliance and provide CE Marking for their product.

2.3 Applicable reference documents

Installation Guide	Seagate P/N 77767475
SCSI Interface Manual	Seagate P/N 77738479

ANSI Small Computer System Interface (SCSI): Document Number ANSI3.131-1986 (X3T9/84.40 Rev. 1B) (X3T9.2/82-2 Rev. 17B), X3T9.2/86-109 Revision 10H (SCSI-2) and X3T9.2-184 Rev. 4 (SCSI-3).

Package Test Specification	Seagate P/N 30190-001 (under 100 lb.)
Package Test Specification	Seagate P/N 30191-001 (over 100 lb.)

In case of conflict between this document and any referenced document, this document takes precedence.

3.0 General description

The drives are a member of a family of low cost, high performance, highly reliable, random access storage devices designed to meet the needs of the OEM marketplace.

The drive records and recovers data on 3.7 inch (95 mm) fixed discs.

The drive supports the Small Computer System Interface as described in the ANSI SCSI-1, SCSI-2 and SCSI-3 Interface Manuals to the extent described in this product Manual (Vol. 1), which defines the product performance characteristics of the Hawk 2LP Family of drives, and the SCSI Interface Product Manual P/N 77738479 (Vol. 2, Version 2) which describes the general interface characteristics of this and other families of Seagate 3.5-inch drives.

The drive interface supports multiple initiators, disconnect/reconnect, self configuring host software and automatic features that relieve the host from the necessity of knowing the physical characteristics of the targets (logical block addressing is used).

The Head/Disc Assembly (HDA) is environmentally sealed at the factory. Air recirculates within the Head/Disc (HDA) through a nonreplaceable filter to maintain a contamination free head/disc environment.

Refer to Figure 3.0-1 an exploded view of the drive. NEVER disassemble the Head/Disc Assembly (HDA). This exploded view is for information only. Do not attempt to service items in the sealed environmental enclosure (heads, media, actuator, etc.) as this requires special facilities. The drive contains no parts replaceable by the user. The drive warranty is voided if the HDA is opened.

The Hawk 2LP Family drives use a dedicated landing zone at the innermost radius of the media to eliminate the possibility of destroying or degrading data by landing in the data zone. The drive automatically goes to the landing zone when the power is removed.

The Hawk 2LP Family drives incorporate an automatic shipping lock which prevents potential damage to the heads and discs that result from movement during shipping and handling. The shipping lock is automatically disengaged when power is applied to the drive and the head load process begins.

The Hawk 2LP Family drives decode track location from the dedicated servo surface to eliminate mechanical transducer adjustments and related reliability concerns.

The Hawk 2LP Family drives use a high performance actuator assembly that consists of a low inertia, balanced, patented, straight arm design that provides excellent performance with minimum power dissipation.

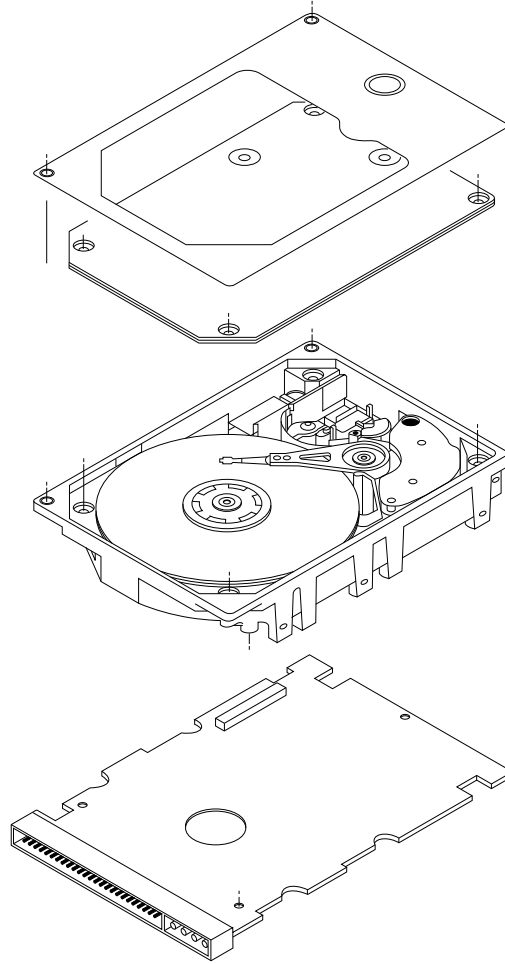

Figure 3.0-1. Hawk 2LP family drive

4.0 Features

The Hawk 2LP Family has the following standard features:

- Integrated SCSI Controller
- Single Ended and Differential SCSI drivers and receivers
- Asynchronous and Synchronous data transfer protocol
- Firmware downloadable via SCSI interface
- Selectable sector size from 256 to 4096 bytes/sector
- Programmable sector reallocation scheme
- Flawed sector reallocation at format time
- Programmable auto write and read reallocation
- Reallocation of defects on command (Post Format)
- 96 bit Reed-Solomon error correcting code
- Sealed Head/Disc Assembly
- No preventative maintenance or adjustment required
- Dedicated head landing zone
- Automatic shipping lock
- Automatic Adaptive Thermal Compensation
- Patented Tri-phase Servo with embedded Grey Code Track Address to guarantee servo positioning.
- Self diagnostics performed at power on
- 1:1 Interleave
- Zoned Bit Recording (ZBR)
- Vertical, horizontal, or top down mounting
- Dynamic spindle brake
- Permanently mounted terminators on "N" models, enabled by installation of a jumper plug.
- 512 K byte data buffer

4.1 Performance

- Programmable multi-segmentable cache buffer
- 5411 RPM Spindle. Average latency = 5.54 ms
- Command Queuing of up to 64 commands
- Background processing of queue
- Supports start and stop commands
- Low audible noise for office environment
- Low power consumption

4.2 Reliability

- 800,000 hour MTBF
- Adaptive servo calibration for improved seek performance
- LSI circuitry
- Balanced low mass rotary voice coil actuator
- 5 year warranty

4.3 Unformatted and formatted capacities

Formatted capacity depends on the number of spare reallocation sectors reserved and the number of bytes per sector. The following table shows some *typical* 512 byte sector size [1] formatted capacities.

	ST32430N/ND GB	ST31230N/ND GB
Spare Sector or Cylinders Reserved for reallocation		
No Spares	2.16	1.07
Five Spare Sectors per Cylinder [2]		1.06
Nine Spare Sectors per Cylinder [2]	2.14	
2 Spare Cylinders per Unit [3]	2.16	1.07
One Spare Sector per Cylinder and 2 Spare Cylinder per Unit [3]	2.16	1.06
Unformatted Capacity	2.59	1.28

Notes.

[1] Sector size selectable at format time. Users having the necessary equipment may modify the data block size before issuing a format command and obtain different formatted capacities than those listed. User available capacity depends on spare reallocation scheme selected. See Mode Select Command and Format Command in the SCSI Interface Product Manual P/N 77738479.

[2] All spare sectors are on one track.

[3] Spare cylinders are on the two inner tracks.

The standard OEM model is as follows:

	Formatted Data Block Size 512 Byte/Sector	Unformatted
ST32430N/ND	2.14 GB*	2.59 GB
ST31230N/ND	1.06 GB*	1.28 GB

* Sparring equivalent to one spare sector per head (all spare sectors are on one track), two spare cylinders/unit.

Installation Guide P/N 77767473 is shipped with each drive unless otherwise requested.

4.4 Options (factory installed)

The capacities shown in paragraph 4.3 are available upon request. Other capacities can be ordered depending on sparing scheme and sector size requested.

The following options are incorporated at the time of production. See Section 12.0.

- Front panel (green LED) - See Figure 3.0-1
- Single Unit shipping pack

4.5 Optional accessories (user installed)

The following accessories are available. All kits may be installed in the field. See Section 13.0.

- Front Panel Kit (with green LED) - See Figure 3.0-1
- Single Unit shipping pack kit
- Adapter Accessory Frame Kit P/N 75790701 (adapts 3.5-inch drive to fit in 5.25-inch drive mounting space)

4.6 Installation

For option jumper locations and definitions refer to Figure 10.1-1. Drive default mode parameters are not normally needed for installation. Refer to Section 11.3.2 for default mode parameters if they are needed.

- Ensure that the SCSI ID of the drive is not the same as the host adapter. Most host adapters use SCSI ID 7.
- If multiple devices are on the bus set the drive SCSI ID to one that is not presently used by other devices on the bus.
- If the drive is the only device on the bus, attach it to the end of the SCSI bus cable. Permanently installed terminators must be enabled on the drive for "N" models using jumper plug **TE**. On "ND" models, external terminators must be provided by the user, systems integrator or host equipment manufacturer.
- If the drive is attached to a bus that contains other devices, and the new drive is not attached to the end of the bus, the Terminator Enable jumper (**TE**) should be removed from the new drive.
- Set all appropriate option jumpers for desired operation prior to power on. If jumpers are changed after power has been applied, recycle the drive power to make the new settings effective.
- Installation instructions are provided by host system documentation or with any additionally purchased drive installation software. If necessary see section 14.0 for Seagate support services telephone numbers.
- The Manufacturers installed labels must not be removed from the drive or covered with additional labels, as they contain information required when servicing the product.

Formatting

- It is not necessary to low level format this drive. The drive is shipped from the factory low level formatted in 512 byte sectors.
- Reformat the drive if one of the following occurs.
 - A different sector size is selected.
 - A different spare sector allocation scheme is selected.

5.0 Performance characteristics

5.1 Internal drive characteristics (transparent to user)

	ST32430N/ND	ST31230N/ND	
Drive Capacity	2.59	1.28	GByte (UNF)*
Read/Write Heads	9	5	
Bytes/Track	72000	64242	Bytes (Avg)*
Bytes/Surface	287.7	255.6	Mbytes (UNF)
Tracks/Surface, Total	3992	3992	Tracks (user accessible)
Tracks/Inch	4200	4200	TPI
Servo Heads	1	1	
Internal Data Rate	35.8 - 62.2	33.9 - 56.7	Mbits/sec (variable with zone)
Disc Rotational Speed	5411± 0.5%	5411 ±0.5% ...	r/min
Average Rotational Latency	5.54	5.54	ms

*Rounded off values.

5.2 SCSI Seek, Read and Write performance characteristics (visible to user) [8]*

The values given in section 5.2 apply to all models of the Hawk 2LP family unless otherwise specified. Refer to Section 11.7 and to the SCSI-2 Interface Product Manual 77738479 for additional timing details.

5.2.1 Access time

		Including Controller Overhead (without disconnect) [1] [4]	
		Drive Level	
		Read	Write
		ms	
Average	-		
	Typical [3]	10.4	
	Max. [2]	11.9	11.4 13.4
Single Track	-		
	Typical [3]	2.1	2.5

5.2.2 Format drive command execution time (minutes) [1]*

	ST32430N/ND	ST31230N/ND
Maximum (with verify)	45	25
Maximum (no verify)	31	15

**5.2.3 Read data command execution time [4]
(512 byte sector size, without disconnect and with read look ahead cache disabled.)
Latency time is included.**

a. From CDB reception to the drive request for the first data byte to be transferred to the Host

1. Typical (Zero Stroke Seek) 7.32 ms [3]*
2. Typical (Average Seek) 17.14 ms [3]
3. Maximum (Full Stroke Seek) 31.78 ms [2]

b. Single Sector Read and Transfer of data to Host (time from receipt of last byte of the CDB to the request for a status byte transfer to Host) [7].

1. Typical (Zero Stroke Seek) 7.42 ms [3]
2. Typical (Average Seek) 17.24 ms [3]
3. Maximum (Full Stroke Seek) 31.84 ms [2]

**5.2.4 Write data command execution time [4]
(512 byte sector size, without disconnect and with read look ahead disabled.)
Latency time is included.**

a. From CDB reception to the request for the first byte of write data from the Host.

1. Typical 1.49 ms
2. Maximum 1.61 ms

b. Single Sector Write and Data Transfer from Host [7] [6]

(Time from receipt of the last byte of the CDB to the request for a completion status transfer to the Host)

1. Typical (Zero Stroke Seek) 7.72 ms [3]
2. Typical (Average Seek) 17.29 ms [3]
3. Maximum (Full Stroke Seek) 32.28 ms [2]

*[] All notes are listed in Section 5.3.1.

5.3 Generalized performance characteristics

Minimum Sector Interleave (All Hawk 2LP models) 1 to 1

Data transfer rate (< 1 sector) - 512 Byte Sector, Data Buffer To/From Disc Media:

ST32430N/ND			ST31230N/ND		
Min.	[4]*	4.48 MByte/sec			4.23 MByte/sec
Avg.	[4]	6.50 MByte/sec			5.79 MByte/sec
Max.	[4]	7.78 MByte/sec			7.09 MByte/sec

Data Transfer Rate (< 1 Track) - 512 Byte Sector, Data Buffer To/From Disc Media:

ST32430N/ND			ST31230N/ND		
Min.	[4]	3.76 MByte/sec divided by (Interleave Factor)			3.56 MByte/sec
Avg.	[4]	5.46 MByte/sec divided by (Interleave Factor)			4.87 MByte/sec
Max.	[4]	6.54 MByte/sec divided by (Interleave Factor)			5.96 MByte/sec

SCSI Interface Data Transfer Rate (Asynchronous) [5] (All Hawk 2LP models)

	N family	ND family
-Maximum Instantaneous	5.2 [9] MBytes/sec	3.3 MBytes/sec
-Maximum Average	3.1 MBytes/sec	2.4 MBytes/sec

The remainder of the specifications of section 5.3 apply to all Hawk 2LP models:

Sector Sizes 512 byte user data blocks (default)
Variable (256 to 4096 bytes per sector) in even number of bytes per sector. If n (number of bytes per sector) is odd, then n-1 will be used.

Synchronous Transfer Rate

From 1.25 MBytes/sec to 10.0 MBytes/sec (See section 11.5.)

Read/Write consecutive sectors on a track	YES
Flaw reallocation performance impact (For flaws reallocated at format time using the spare sectors per track reallocation scheme.) [10]	Negligible
Flaw reallocation performance impact (For flaws reallocated at format time using the spare sectors per cylinder reallocation scheme.) [10]	Negligible
Flaw reallocation performance impact (For flaws reallocated at format time using the spare tracks per volume reallocation scheme.)	35 ms (typical)
Overhead time for head switch (512 byte sectors)	1 ms
Overhead time for one track cylinder switch	<3 ms Typical
Average rotational latency	5.54 ms

*[] Notes listed in Section 5.3.1

5.3.1 Notes for sections 5.2 and 5.3.

- [1] Execution time measured from receipt of the last Byte of the Command Descriptor Block (CDB) to the request for a Status Byte Transfer to the Initiator (excluding connect/disconnect).
- [2] Maximum times are specified over the worst case conditions of temperature, voltage margins and drive orientation. When comparing specified access times, care should be taken to distinguish between typical access times and maximum access times. The best comparison is obtained by system benchmark tests conducted under identical conditions. Maximum times do not include error recovery.
- [3] Typical Access times are measured under nominal conditions of temperature, voltage, and horizontal orientation as measured on a representative sample of drives.
- [4] Assumes no errors and no sector has been relocated.
- [5] Rate measured from the start of the first sector transfer to or from the Host.
- [6] Assumes the Initiator immediately sends Write Data to the drive when requested.
- [7] Command execution requires a data transfer phase (data to or from the disc media). Assumes the initiator is instantly ready to send or receive the data when the drive generates first request for a data byte transfer, and assumes an average data transfer rate between the drive and the Initiator as specified in section 5.3.
- [8] All performance characteristics assume that automatic adaptive temperature compensation is not in process when the SCSI command is received. The following paragraphs give highlights of thermal calibration operation.
 - a. At spin-up, all heads are calibrated on the outer and inner diameter calibration tracks.
 - b. A timed calibration occurs 1 minute after spin-up, and every 10 minutes thereafter. During these timed calibrations, the firmware alternates between the inner and outer diameter calibration tracks. For example, all heads are calibrated on the inner track, then 10 minutes later all heads are calibrated on the outer track. Automatic adaptive temperature calibration does not interrupt SCSI commands being executed.
 - c. If automatic adaptive thermal calibration is in process when the drive receives a SCSI command, the drive queues the command until the compensation for the specific head being compensated completes. When compensation completes for the specific head being compensated, the drive executes the first queued command. When execution of the first queued command completes, the drive continues compensation for the remaining head(s). The above procedure continues until the drive completes compensation for all heads.
 - d. When a timed calibration comes due, the drive postpones the calibration until the drive has been idle for 25 to 50 milliseconds.
 - e. When the drive receives a Write command, the drive performs a single head calibration if a calibration has been delayed for 1 to 5 minutes. The drive performs an uninterruptible calibration of all heads if the calibration has been delayed more than 5 minutes.
 - f. The drive performs a calibration of all heads prior to the first retry of any media error if a timed calibration has been delayed for over one minute.
 - g. Automatic adaptive temperature compensation takes less than 0.1% of bus time.
 - h. Automatic adaptive temperature compensation occurs at times other than mentioned above, but should be transparent to the user (e.g., during execution of Format, Rezero, and Reassign Block commands).
 - i. A rezero command can be used to reset the Automatic adaptive temperature compensation timer back to start so that the host can know when the interruption for timed thermal compensation will occur.
- [9] Assumes system ability to support 5.2 Mb/s and no cable loss.
- [10] Simulated.

*SCSI commands are described in the SCSI Interface manual, 77738479.

5.4 Start/stop time

After DC power has been applied, the drive becomes ready within 20 seconds (15 seconds typical) if the Motor Start Option is disabled (i.e. the motor starts as soon as the power has been applied). During this time the drive responds to some commands over the SCSI interface* in less than 3 seconds. Stop time is less than 20 seconds from removal of DC power.

If the Motor Start Option is enabled, the internal controller accepts the commands listed in the SCSI Interface Product Manual* less than 3 seconds after DC power has been applied. After the Motor Start Command has been received the drive becomes ready for normal operations within 13 seconds typically. The Motor Start Command can also be used to command the drive to stop the spindle*.

There is no power control switch on the drive.

5.5 Prefetch/multi segmented cache control

The drive provides prefetch (read look-ahead) and multi-segmented cache control algorithms that in many cases can enhance system performance. "Cache" as used herein refers to the drive buffer storage space when it is used in "cache" operations. To select prefetch and cache features the host sends the Mode Select command with the proper values in the applicable bytes in Mode Page 08h*. Prefetch and cache operation are independent features from the standpoint that each is enabled and disabled independently via the Mode Select command. However, in actual operation the prefetch feature overlaps cache operation somewhat as is noted in sections 5.5.1 and 5.5.2.

All default cache and prefetch Mode parameter values (Mode Page 08h) for standard OEM versions of this drive family are given in Tables 11.3.2-1 through 11.3.2-4.

5.5.1 Cache operation

In general, 480 Kbytes of the 512 Kbytes of physical buffer space in the drive can be used as storage space for cache operations. The buffer can be divided into logical segments (Mode Select Page 08h, byte 13) from which data is read and to which data is written. The drive maintains a table of logical block disk medium addresses of the data stored in each segment of the buffer. If cache operation is enabled (RCD bit = 0 in Mode Page 08h, byte 2, bit 0. See SCSI Interface Product Manual*), data requested by the host with a Read command is retrieved from the buffer (if it is there), before any disc access is initiated. If cache operation is not enabled, the buffer (still segmented with required number of segments) is still used, but only as circular buffer segments during disc medium read operations (disregarding Prefetch operation for the moment). That is, the drive does not check in the buffer segments for the requested read data, but goes directly to the medium to retrieve it. The retrieved data merely passes through some buffer segment on the way to the host. On a cache "miss", all data transfers to the host are in accordance with "buffer-full" ratio rules. On a cache "hit" the drive ignores the "buffer-full" ration rules. See explanations associated with Mode page 02h (disconnect/reconnect control) in the SCSI Interface Product Manual*.

The following is a simplified description of a read operation with cache operation enabled:

Case A - A Read command is received and the first logical block (LB) is already in cache:

1. Drive transfers to the initiator the first LB requested plus all subsequent contiguous LB's that are already in the cache. This data may be in multiple segments.
2. When the requested LB is reached that is not in any cache segment, the drive fetches it and any remaining requested LB's from the disc and puts them in a segment of the cache. The drive transfers the remaining requested LB's from the cache to the host in accordance with the disconnect/reconnect specification mentioned above.
3. If the prefetch feature is enabled, refer to section 5.5.2 for operation from this point.

*SCSI Interface Product Manual, 77738479.

Case B - A Read command requests data, the first LB of which is not in any segment of the cache:

1. The drive fetches the requested LB's from the disc and transfers them into a segment, and from there to the host in accordance with the disconnect/reconnect specification referred to in case A.
2. If the prefetch feature is enabled, refer to section 5.5.2 for operation from this point.

Each buffer segment is actually a self-contained circular storage (wrap-around occurs), the length of which is an integer number of disc medium sectors. The wrap-around capability of the individual segments greatly enhances the buffer's overall performance as a cache storage, allowing a wide range of user selectable configurations, which includes their use in the prefetch operation (if enabled), even when cache operation is disabled (see section 5.5.2). The *number* of segments may be selected using the Mode Select command, but the size can not be directly selected. Size is selected only as a by-product of selecting the segment number specification. The size in Kbytes of each segment is reported by the Mode Sense command page 08h, bytes 14 and 15. If a size specification is sent by the host in a Mode Select command (bytes 14 and 15) no new segment size is set up by the drive, and if the "STRICT" bit in Mode page 00h (byte 2, bit 1) is set to one, the drive responds as it does for any attempt to change unchangeable parameters (see SCSI I/O Product Manual*). The drive supports operation of any integer number of segments from 1 to 16.

5.5.2 Prefetch operation

If the Prefetch feature is enabled, data in contiguous logical blocks on the disc immediately beyond that which was requested by a Read command can be retrieved and stored in the buffer for immediate transfer from the buffer to the host on subsequent Read commands that request those logical blocks (this is true even if "cache" operation is disabled). Though the prefetch operation uses the buffer as a "cache", finding the requested data in the buffer is a prefetch "hit", not a "cache" operation "hit". Prefetch is enabled using Mode Select page 08h, byte 12, bit 5 (Disable Read Ahead - DRA bit). DRA bit = 0 enables prefetch. Since data that is prefetched replaces data already in some buffer segment(s), the host can limit the amount of prefetch data to optimize system performance. The max prefetch field (bytes 8 and 9) limits the amount of prefetch. The drive does not use the prefetch "ceiling" field (bytes 10 and 11).

During a prefetch operation, the drive crosses a cylinder boundary to fetch more data only if the Discontinuity (DISC) bit is set to one in bit 4 of byte 2 of Mode parameters page 08h.

Whenever prefetch (read look-ahead) is enabled (enabled by DRA = 0), it operates under the control of ARLA (Adaptive Read Look-Ahead). ARLA enables prefetch of contiguous blocks from the disk when it senses that a prefetch "hit" will likely occur, even if two consecutive read operations were not for physically contiguous blocks of data (e.g. "software interleave"). ARLA disables prefetch when it decides that a prefetch "hit" will not likely occur. If the host is not using software interleave, and if two sequential read operations are not for contiguous blocks of data, ARLA disables prefetch, but as long as sequential read operations request contiguous blocks of data, ARLA keeps prefetch enabled.

*SCSI Interface Product Manual, P/N 77738479.

5.6 Caching write data

Write caching is a write operation by the drive that makes use of a drive buffer storage area where the data to be written to the medium is stored in one or more segments while the drive performs the write command.

Write caching is enabled along with read caching. For write caching, the same buffer space and segmentation is used as set up for read functions. The buffer segmentation scheme is set up or changed independently, having nothing to do with whether or not read and write caching is enabled or disabled. When a write command is issued, the cache is first checked to see if any logical blocks that are to be written are already stored in the cache from a previous read or write command. If there are, the respective cache segments are cleared. The new data is cached for subsequent Read commands.

If the number of write data logical blocks exceeds the size of the segment being written into when the end of the segment is reached, the data is written into the beginning of the same cache segment, overwriting the data that was written there at the beginning of the operation. However, the drive does not overwrite data that has not yet been written to the medium.

Tables 11.3.2-1 through 11.3.2-4 show Mode default settings for the drives.

6.0 Reliability specifications

The following reliability specifications assume correct host/drive operational interface, including all interface timings, power supply voltages, and environmental requirements.

Seek Errors	Less than 1 in 10^7 seeks
Read Error Rates [1]	
Unrecovered Data	Less than 1 sector in 10^{14} bits transferred
Miscorrected Data	Less than 1 sector in 10^{21} bits transferred
MTBF	800,000 hours
Service Life	5 years
Preventive Maintenance	None required

Note.

[1] Error rate specified with automatic retries and data correction with ECC enabled and all flaws reallocated.

6.1 Error rates

The error rates stated in this specification assume the following:

- a. The drive is operated per this specification using DC Power as defined in this Manual (see Section 7.2).
- b. The drive has been formatted with the SCSI FORMAT commands.
- c. Errors caused by media defects or host system failures are excluded from error rate computations. Refer to Paragraph 8.0, Media Characteristics.

6.1.1 Read errors

Before determination or measurement of read error rates:

- a. The data that is to be used for measurement of read error rates must be verified as being written correctly on the media.
- b. All media defect induced errors must be excluded from error rate calculations.

6.1.2 Environmental interference

When evaluating systems operation under conditions of Electromagnetic Interference (EMI), the performance of the drive within the system shall be considered acceptable if the drive does not generate an unrecoverable condition.

An unrecoverable error, or condition, is defined as one that:

1. Is not detected and corrected by the drive itself;
2. Is not capable of being detected from the error or fault status provided through the drive or SCSI interface;
or
3. Is not capable of being recovered by normal drive or system recovery procedures without operator intervention.

6.1.3 Write errors

Write errors can occur as a result of media defects, environmental interference, or equipment malfunction. Therefore, write errors are not predictable as a function of the number of bits passed.

If an unrecoverable write error occurs because of an equipment malfunction in the drive, the error is classified as a failure affecting MTBF. Unrecoverable write errors are those which cannot be corrected within two attempts at writing the record with a read verify after each attempt (excluding media defects).

6.1.4 Seek errors

A seek error is defined as a failure of the drive to position the heads to the addressed track. There shall be no more than one recoverable seek error in 10^7 physical seek operations. After detecting an initial seek error, the drive automatically reseek to the addressed track up to 3 times. If a reseek is successful, the Extended Sense reports a seek positioning error (15h), no seek complete error (02h), or track follow error (09h), and the sense key reports a recovered error (1h). If all three reseek fail, a seek positioning error (15h) is reported with a Medium (3h) or Hardware error (4h) reported in the Sense Key. This is an unrecoverable seek error. Unrecoverable seek errors are classified as failures for MTBF calculations. Ref. section 5.1.1.2 of SCSI-2 Interface Product Manual P/N 77738479.

6.2 Reliability and service

6.2.1 Mean time between failure

The production disc drive shall achieve an MTBF of 800,000 hours when operated in a benign atmosphere at an average disc drive ambient temperature of 95°F (35°C) or less as measured per this Product Manual, paragraph 7.4.1. Short term excursions up to the specification limits of the operating environment will not affect MTBF performance.

The following expression defines MTBF:

$$\text{MTBF per measurement period} = \frac{\text{Estimated power-on operating hours in the period}}{\text{Number of drive failures in the period}}$$

Estimated power-on operation hours means power-up hours per disc drive times the total number of disc drives in service. Each disc drive shall have accumulated at least nine months of operation. Data shall be calculated on a rolling average base for a minimum period of six months.

Drive failure means any stoppage or substandard performance caused by drive malfunction.

6.2.2 Preventive maintenance

No routine scheduled preventive maintenance shall be required.

6.2.3 Service life

The drive shall have a useful service life of five years. Depot repair or replacement of major parts is permitted during the lifetime (6.2.4).

6.2.4 Service philosophy

Special equipment is required to repair the drive HDA. In order to achieve the above service life, repairs must be performed only at a properly equipped and staffed service and repair facility. Troubleshooting and repair of PCBs in the field is not recommended, because of the extensive diagnostic equipment required for effective servicing. Also, there are no spare parts available for this drive. Drive warranty is voided if the HDA is opened.

6.2.5 Installation

The drive is designed, manufactured, and tested with a "Plug in and Play" installation philosophy. This philosophy minimizes the requirements for highly trained personnel to integrate the drive into the OEM's system, whether in a factory or field environment.

The drive has been low level formatted at the factory and need not be reformatted.

6.2.6 Service tools

No special tools are required for site installation or recommended for site maintenance. Refer to Paragraph 6.2.4. The depot repair philosophy of the drive precludes the necessity for special tools. Field repair of the drive is not practical since there are no user purchasable parts in the drive.

6.2.7 Product warranty

Beginning on the date of shipment to customer and continuing for a period of five years, Seagate warrants that each product (including components and subassemblies) or spare part that fails to function properly under normal use due to defect in materials or workmanship or due to nonconformance to the applicable specifications will be repaired or replaced, at Seagate's option and at no charge to customer, if returned by customer at customer's expense to Seagate's designated facility in accordance with Seagate's Warranty Procedure. Seagate will pay for transporting the repair or replacement item to customer. For more detailed warranty information refer to the Standard terms and conditions of Purchase for Seagate products.

Shipping:

When transporting or shipping a drive, a Seagate approved container must be used. Keep your original box. They are easily identified by the Seagate Approved Package label. Shipping a drive in a non-approved container voids the drive warranty.

Seagate repair centers may refuse receipt of components improperly packaged or obviously damaged in transit. Contact your Authorized Seagate Distributor to purchase additional boxes. Seagate recommends shipping by an air-ride carrier experienced in handling computer equipment.

Product repair and return information

Seagate customer service centers are the only facilities authorized to service Seagate drives. Seagate does not sanction any third-party repair facilities. Any unauthorized repair or tampering with the factory-seal voids the warranty.

7.0 Physical/electrical specifications

7.1 AC power requirements: None

7.2 DC power requirements

The voltage and current requirements for a single drive are shown in the following table. Values indicated apply at the drive power connector. The single ended power requirements includes the internal disc drive SCSI I/O termination.

Table 7.2-1. DC power requirements

	ST32430				ST31230			
	Single Ended		Differential I/O		Single Ended		Differential I/O	
Voltage	+5 V	+12 V	+5 V	+12V	+5 V	+12 V	+5 V	+12V
Regulation [4] [2]	±5%	±5%	±5%	±5%	±5%	±5%	±5%	±5%
Average Idle Current [1]	0.36 A	0.35 A	0.51 A	0.35 A	0.36 A	0.35 A	0.51 A	0.35 A
Maximum Starting Current (Peak) [5][2][6]	0.61 A	2.0 A	0.71 A	2.0 A	0.61 A	2.0 A	0.71 A	2.0 A
Delayed Motor Start (Max) [3][5]	0.56 A	0.22 A	0.56 A	0.22 A	0.56 A	0.22 A	0.56 A	0.22 A
Operating Current [6]								
Typ. [1]	0.80 A	0.40 A	0.90 A	0.40 A	0.80 A	0.40 A	0.90 A	0.40 A
Max. [1]	0.85 A	0.42 A	1.05 A	0.42 A	0.85 A	0.42 A	1.05 A	0.42 A
Max. (Peak)	1.1 A	1.9 A	1.3 A	1.9 A	1.1 A	1.9 A	1.3 A	1.9 A

- [1] Measured with average reading DC ammeter. Instantaneous current peaks will exceed these values.
 [2] A droop of up to -10% is permissible during the T2 portion of power up (see Figure 7.2.2-1).
 [3] This condition occurs when the Motor Start Option is enabled and the drive has not yet received a Start Motor command.
 [4] See paragraph 7.2.1 "Conducted Noise Immunity".
 [5] Peaks of 0.90 A (nominal) on +12 V will occur for no more than 100 ms total during the first 250 ms after power is applied.
 [6] Instantaneous peaks in excess of these values and less than 5 msec. in duration are allowed.

General Notes from Table 7.2-1:

- At powerup, the motor current regulator limits the 12 volt current to a peak value of less than 1.9 amperes, although instantaneous peaks may occur as stated in [7] above.
- Operating condition is defined as random seek read of 64 blocks.
- Minimum operating current loading for each supply voltage is not less than 38% of the maximum operating current shown.
- The +5 and +12 volt supplies shall employ separate ground returns.
- Where power is provided to multiple drives from a common supply, careful consideration for individual drive power requirements should be noted. Where multiple units are powered on simultaneously, the peak starting current must be available to each device.

7.2.1 Conducted noise immunity

Noise is specified as a periodic and random distribution of frequencies covering a band from DC to 10 mHz. Maximum allowed noise values given below are peak to peak measurements and apply at the drive power connector.

- +5 V = 150 mV pp from 0 to 50 kHz and 45 mA pp from 50 kHz to 10 mHz.
 +12 V = 150 mV pp from 0 to 50 kHz and 60 mA pp from 50 kHz to 10 mHz.

7.2.2 Power sequencing

The drive does not require power sequencing. The drive protects against inadvertent writing during power up and down. Daisy-chain operation requires that power be maintained on the terminated drive to ensure proper termination of the peripheral I/O cables.

7.2.3 12 V - current profile

Figure 7.2.2-1 identifies the drive +5 V and +12 V current profile. The current during the various times is as shown:

T -Power is applied to the drive.

T1 -Controller self tests are performed.

T2 -Spindle begins to accelerate under current limiting after performing drive internal diagnostics. See Note 1 of Table 7.2-1.

T3 -The spindle is up to speed and the Head-Arm restraint is unlocked.

T4 -The heads move from the landing zone to the data area.

T5 -The adaptive calibration sequence is performed.

T6 -Calibration is complete and the drive is ready for reading and writing.

Note. All times and currents are typical. See Table 7.2-1 for maximum current requirements.

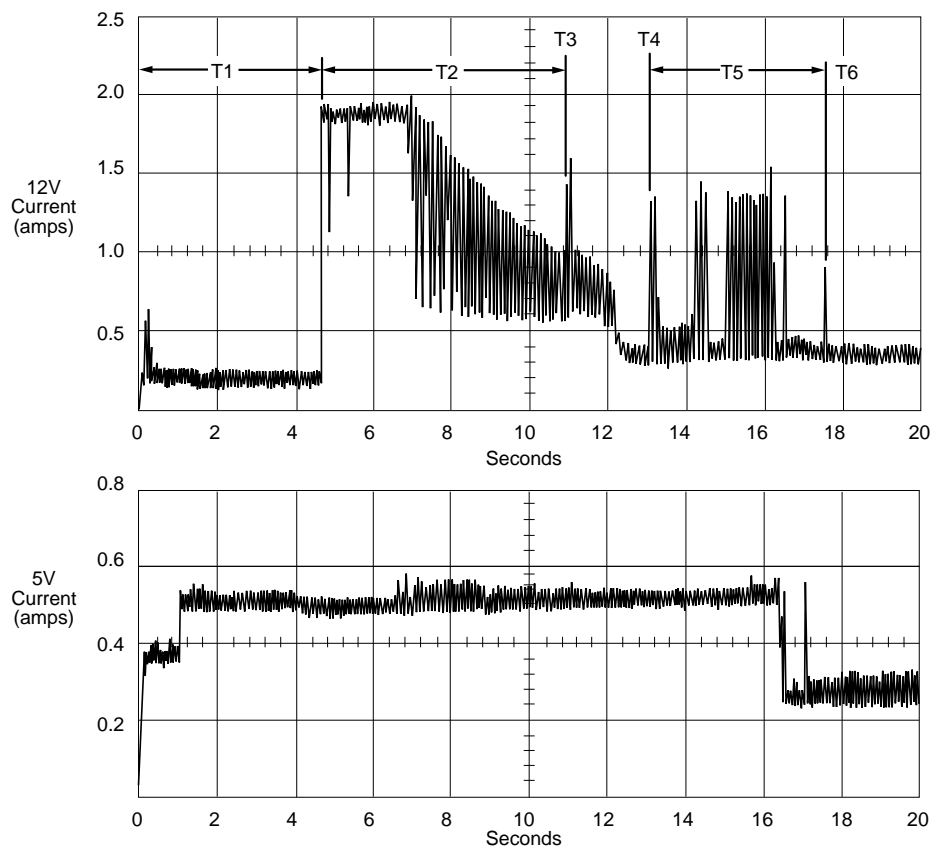

Figure 7.2.2-1. Typical Hawk 2LP family drive +5 V and +12 V current profile

7.3 Heat/power dissipation

For drives with single ended interface circuits, typical operating random read power dissipation is 9.0 watts (30.8 BTUs per hour) of DC power average at nominal voltages. Typical power dissipation under idle conditions is 6.0 watts (20.5 BTUs per hour).

For drives with differential interface circuits, typical operating random read power dissipation is 9.5 watts (32.5 BTUs per hour) of DC power average at nominal voltages. Typical power dissipation under idle conditions is 6.75 watts (23.1 BTUs per hours).

7.4 Environmental limits

Temperature and humidity values experienced by the drive must be such that condensation does not occur on any drive part. Altitude and atmospheric pressure specifications are referenced to a standard day at 58.7°F (14.8°C). Maximum Wet Bulb temperature is 82°F (28°C).

7.4.1 Temperature

a. Operating

The drive meets all specifications over a 41°F to 131°F (5°C to 55°C) drive ambient temperature range with a maximum gradient of 36°F (20°C) per hour. The enclosure for the drive should be designed such that the temperatures at the locations specified in Table 7.4.1-1, column 1 are not exceeded. Air flow may be needed to achieve these temperature values. Operation at case temperatures above these values may adversely affect the drives ability to meet specifications.

The MTBF specification for the drive is based on operating at an ambient temperature of 95°F (35°C). Occasional excursions to drive ambient temperatures of 55°C or 5°C may occur without impact to specified MTBF. To achieve the specified MTBF, the values of Table 7.4.1-1 Column 2 must be considered maximum average operating case temperatures. Air flow may be needed to achieve these temperatures. Continual or sustained operation at case temperatures above these values may degrade MTBF.

Table 7.4.1-1. PCB and HDA temperatures

Items in Figure 7.4.1-1	Column 1 Maximum Case Temperatures (°C) Operating (55° Ambient) [2]	Column 2 Typical Case Temperatures (°C) at 35°C Ambient [1]
HDA	65	45
U2	88	68
U31	100	59
U17	101	60
U5	98	58
U3	91	54

Note.

- [1] The temperatures shown in Column 2 were measured on an unmounted drive lying on its side during random write/reads at 100% duty cycle in still air.
- [2] The temperatures in Column 1 are calculated and may not reflect actual operating values. Sufficient cooling air may be required to ensure that these values are not exceeded.

b. Non-Operating

-40° to 158°F (-40° to 70°C) package ambient with a maximum gradient of 45°F (25°C) per hour. This specification assumes that the drive is packaged in the shipping container designed by Seagate for use with drive.

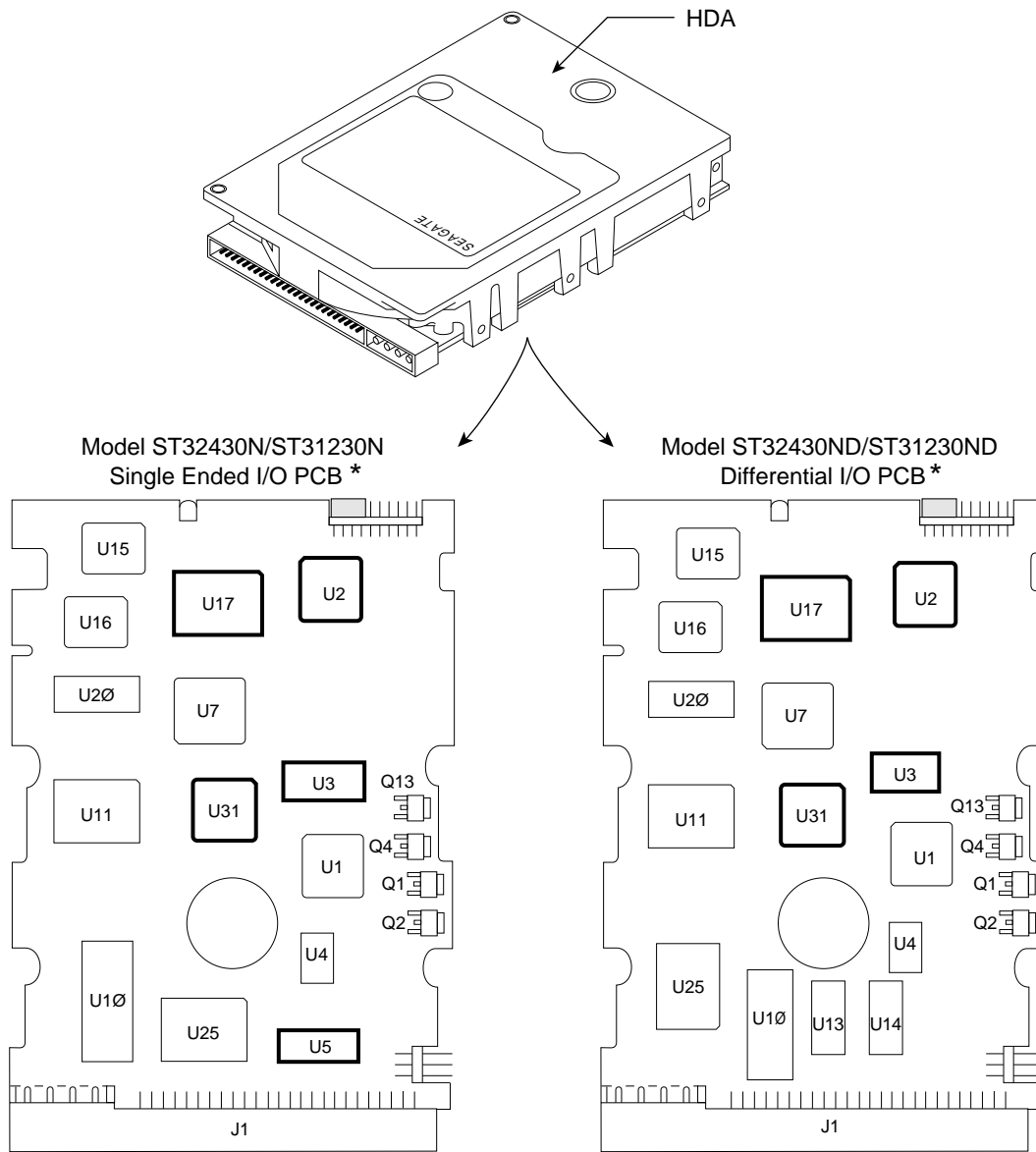

* Bottom side of PCB

Figure 7.4.1-1. Locations of components listed in table 7.4.1-1.

7.4.2 Relative humidity

The values below assume that no condensation on the drive occurs.

- a. Operating
8% to 80% relative humidity with a maximum gradient of 10% per hour.
- b. Non-Operating
5% to 95% relative humidity.

7.4.3 Effective altitude (sea level reference)

- a. Operating
-1000 to +10,000 feet (-305 to +3048 metres)
- b. Non-Operating
-1000 to +40,000 feet (-305 to +12,210 metres)

7.4.4 Shock and vibration

Shock and vibration limits specified in this document are measured directly on the drive chassis. If the drive is installed in an enclosure to which the stated shock and/or vibration criteria is applied, resonance's may occur internally to the enclosure resulting in drive movement in excess of the stated limits. If this situation is apparent, it may be necessary to modify the enclosure to minimize drive movement.

The limits of shock and vibration defined within this document are specified with the drive mounted by any of the four methods shown in Figure 7.4.4-1. Orientation of the side nearest the LED may be up or down.

7.4.4.1 Shock

- a. Operating

The drive, as installed for normal operation, shall operate error free while subjected to intermittent shock not exceeding 10 g's at a maximum duration of 11 ms (half sinewave). Shock may be applied in the X, Y, or Z axis.

- b. Nonoperating

The limits of nonoperating shock shall apply to all conditions of handling and transportation. This includes both isolated drives and integrated drives.

The drive subjected to nonrepetitive shock not exceeding 75 g's at a maximum duration of 11 ms (half sinewave) shall not exhibit device damage or performance degradation. Shock may be applied in the X, Y, or Z axis.

- c. Packaged

The drive as packaged in a single or multiple drive pack of gross weight 20 pounds (8.95 kg) or less by Seagate for general freight shipment shall withstand drop test from heights listed below against a concrete floor or equivalent. For additional details refer to specifications 30190-001 (under 100 lbs) or 30191-001 (over 100 lbs).

Package Size	Drop Height
600 - 1800 in ³ (9,832 - 29,502 cm ³)	48 in (121 cm)
>1800 in ³ (>29,502 cm ³)	42 in (106 cm)

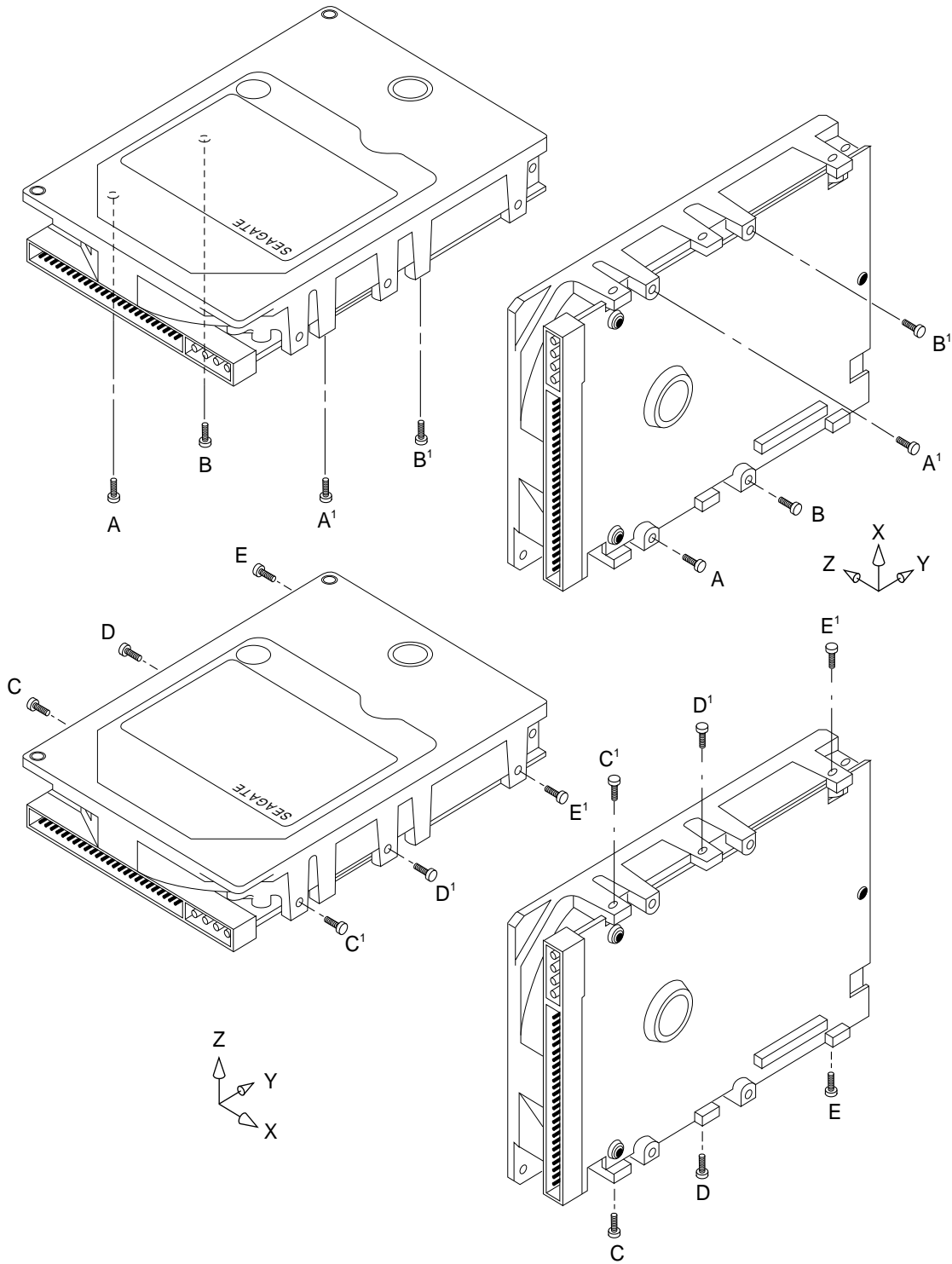

Figure 7.4.4-1. Recommended mounting

7.4.4.2 Vibration

a. Operating

The drive as installed for normal operation, shall comply with the complete specified performance while subjected to continuous vibration not exceeding

5-22 Hz @ 0.020 inches (0.51 mm) displacement

22-400 Hz @ 0.5 g

Vibration may be applied in the X, Y, or Z axis.

b. Nonoperating

The limits of nonoperating vibration shall apply to all conditions of handling and transportation. This includes both isolated drives and integrated drives.

The drive shall not incur physical damage or degraded performance as a result of continuous vibration not exceeding

5-22 Hz @ 0.081 inches (2.05 mm) displacement

22-400 Hz @ 2.00 g

Vibration may be applied in the X, Y, or Z axis.

7.4.5 Air cleanliness

The drive is designed to operate in a typical office environment with minimal environmental control.

7.5 Electromagnetic compatibility

7.5.1 Electromagnetic susceptibility

As a component assembly, the drive is not required to meet any susceptibility performance requirements. It is the responsibility of the system integrator to perform those tests required to ensure that equipment operating in the same system as the drive does not adversely affect the performance of the drive. See section 6.1.2, and see Table 7.2-1, DC Power Requirements.

7.6 Mechanical specifications

The following nominal dimensions are exclusive of the decorative front panel accessory. However, dimensions of the front panel are shown in figure below. Refer to Figure 7.6-1 for detailed mounting configuration dimensions. See section 7.6.3, Drive mounting.

Height:	1.00 in	25.4	mm
Width:	4.00 in	101.6	mm
Depth:	5.74 in	145.8	mm
Weight:	1.5 pounds	0.68	kilograms

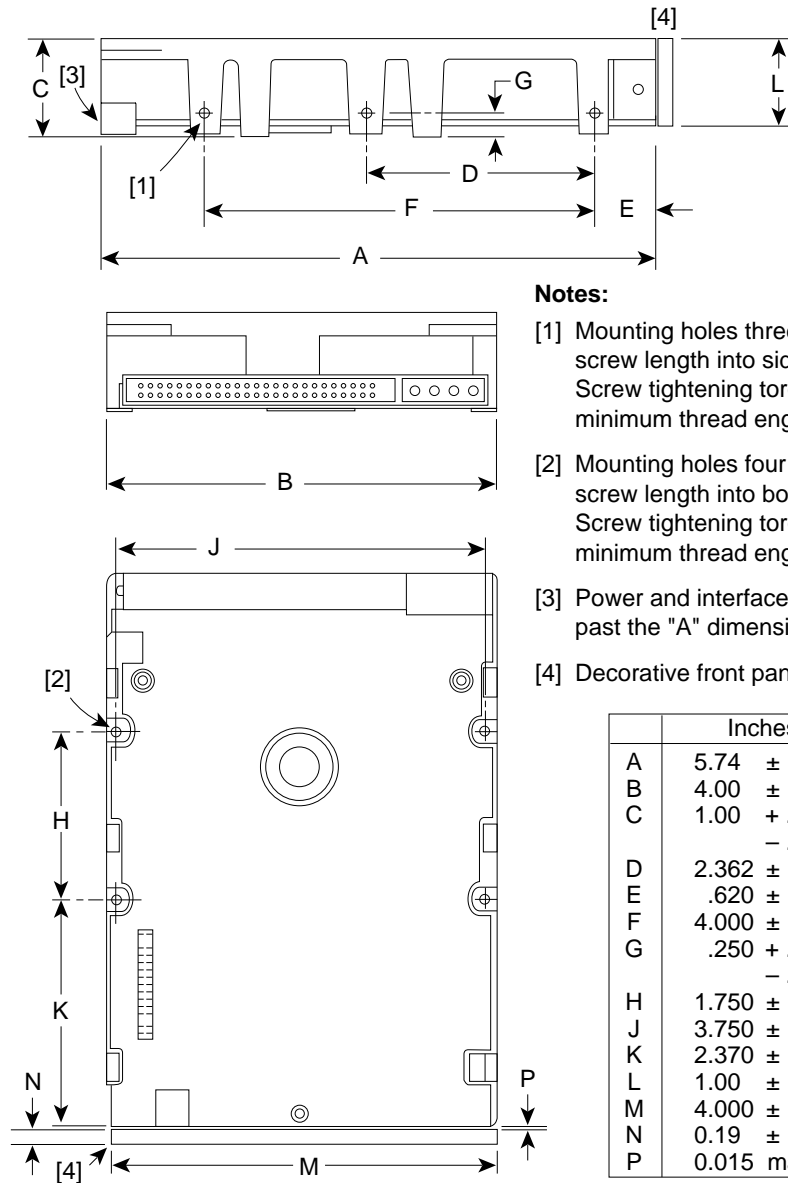

Notes:

- [1] Mounting holes three on each side, 6-32 UNC. Max screw length into side of drive 0.15 in. (3.81 mm). Screw tightening torque 6.0 in-lb (.675 NM) max with minimum thread engagement of 0.12 in. (3.05 mm).
- [2] Mounting holes four on bottom, 6-32 UNC. Max screw length into bottom of drive 0.20 in. (5.08 mm). Screw tightening torque 6.0 in-lb (.675 NM) max with minimum thread engagement of 0.12 in. (3.05 mm).
- [3] Power and interface connectors can extend past the "A" dimension by 0.040 in. (1.02 mm).
- [4] Decorative front panel (optional).

	Inches	Millimeters
A	5.74 ± .010	145.80 ± .25
B	4.00 ± .010	101.60 ± .25
C	1.00 + .026 - .010	25.40 + .66 - .25
D	2.362 ± .010	60.00 ± .25
E	.620 ± .010	15.75 ± .25
F	4.000 ± .010	101.60 ± .25
G	.250 + .010 - .005	6.35 + .25 - .12
H	1.750 ± .010	44.45 ± .25
J	3.750 ± .010	95.25 ± .25
K	2.370 ± .010	60.20 ± .25
L	1.00 ± .010	25.4 ± .25
M	4.000 ± .010	101.6 ± .25
N	0.19 ± .010	4.83 ± .25
P	0.015 max	0.381 max

Figure 7.6-1. Mounting configuration dimensions

7.6.1 Drive orientation

The balanced rotary arm actuator design of the drive allows it to be mounted in any orientation. All drive performance characterization, however, has been done with the drive in horizontal (discs level) and vertical (drive on its side) orientations, and these are the two preferred mounting orientations.

7.6.2 Cooling

Cabinet cooling must be designed by the customer so that the ambient temperature immediately surrounding the drive will not exceed temperature conditions specified in 7.4.1. Specific consideration should be given to make sure adequate air circulation is present around the PCBs to meet the requirements of 7.4.1. Cables should be routed such that they do not block cooling air flow.

7.6.3 Drive mounting

When mounting the drive using the bottom holes care must be taken to ensure that the drive is not physically distorted due to a stiff non-flat mounting surface. The allowable mounting surface stiffness is 80 lb/in (14.0 N/mm). The following equation and paragraph define the allowable mounting surface stiffness:

$$k * x = 80 \text{ lb (14.0 N)}$$

where 'k' represents the mounting surface stiffness (units of lb/in or N/mm), and, 'x' represents the out-of-plane mounting surface distortion (units of inches or millimeters). The out-of-plane distortion ('x') is determined by defining a plane with three of the four mounting points fixed and evaluating the out-of-plane deflection of the fourth mounting point when a known force is applied to the fourth point.

8.0 Media characteristics

8.1 Media description

The media used on the drive has a diameter of approximately 3.7 inches (95 mm). The aluminum substrate is coated with a thin film magnetic material, overcoated with a proprietary protective layer for improved durability and environmental protection.

9.0 Defect and error management

The drive, as delivered, complies with this specification. The read error rate and specified storage capacity are not dependent upon use of defect management routines by the host (initiator).

Defect and error management in the SCSI system involves the drive internal defect/error management and SCSI systems error considerations (errors in communications between Initiator and the drive). Tools for use in designing a defect/error management plan are briefly outlined in this section, with references to other sections where further details are given.

9.1 Drive internal defects/errors

Identified defects are recorded on the drive defects list tracks (referred to as the primary or ETF defect list). These known defects are reallocated during the initial drive format operation at the factory. (See Format Unit command Section 5.2.1.2 in SCSI Interface Product Manual*). Data correction by ECC will be applied to recover data from additional flaws if they occur.

Details of the SCSI commands supported by the drive are described in SCSI Product Interface Manual*. Also, more information on the drive Error Recovery philosophy is presented in Section 6 of the SCSI Interface Product Manual.

9.2 SCSI systems error considerations

Information on the reporting of operational errors or faults across the interface is given in the SCSI Interface Product Manual. Message Protocol System is described in the SCSI Interface Product Manual*. Several of the messages are used in the SCSI systems error management system. The Request Sense command returns information to the host about numerous kinds of errors or faults. The Receive Diagnostic Results reports the results of diagnostic operations performed by the drive.

Status returned by the drive to the Initiator is described in the SCSI Interface Manual*. Status reporting plays a role in the SCSI systems error management and its use in that respect is described in sections where the various commands are discussed.

*SCSI Interface Product Manual P/N 77738479.

10.0 Option/configuration headers

10.1 Drive ID/option select header

Figure 10.1-1 shows a bottom view of the drive (PCB toward viewer) for the purpose of showing the drive ID select and configuration option select jumper connectors. The notes following the figures describe the functions of the various jumper positions on the 3 connectors J2, J5 and J6. Suggested part numbers for the jumpers used on J2 is Molex 52747-0211 (Seagate P/N 77679052).

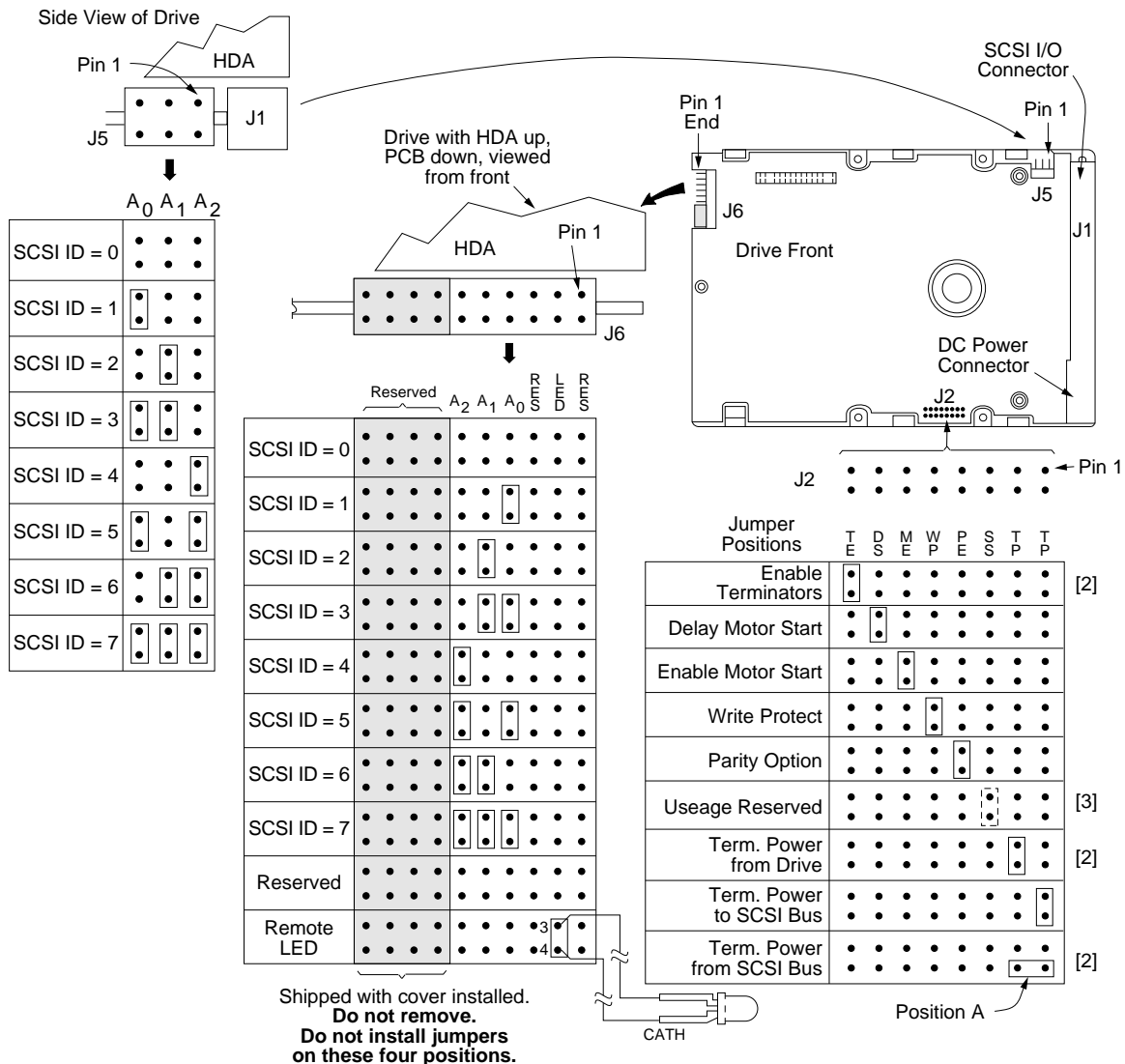

Figure 10.1-1. Hawk 2LP family drive ID and option select header

Notes for Figure 10.1-1.

- [1] Notes explaining the functions of the various jumpers on jumper header connectors J2, J5 and J6 are given below in left to right order of jumper position. The term “**default**” means as standard OEM units are configured when shipped from factory. “Off” means no jumper is installed; “On” means a jumper is installed. Off or on underlined is factory **default** condition.
- [2] “ND” models do not have terminators on the drive PCB, so these jumpers are not applicable.
- [3] Reserved usage. Do not install a jumper.

J2**Jumper****Installation****Jumper Function Description****TE****(Applies only to "N" models)**On

With the jumper installed, the On-board (non-removable) terminator circuits are enabled (connected to the I/O lines). **Default** is jumper installed.

Off

Terminator circuits not connected to I/O lines.

DS**ME**OffOff

Spindle starts immediately after power up - **Default** setting.

Off

On

Drive spindle does not start until Start Unit command received from host.

On

Off

Spindle Startup is delayed by SCSI ID times 12 seconds after power is applied, i.e., drive 0 spindle starts immediately when DC power connected, drive 1 starts after 12 second delay, drive 2 starts after 24 second delay, etc.

On

On

Drive spindle starts when Start Unit command received from host. Delayed start feature is overridden and does not apply when **ME** jumper is installed.

WP

On

Entire drive is write protected.

Off

Drive is not write protected. **Default** is no **WP** jumper installed.

PEOn

Parity checking and parity error reporting by the drive is enabled. **Default** is **PE** jumper installed.

Off

Drive does not report result of parity checking to host.

SSOff

Reserved jumper position. Default is no jumper installed.

TP**TP**

Off

Off

No terminator power is connected to drive terminators or SCSI bus I/O pin 26.

On

Off

Drive supplies its own terminator power only. Jumper on this position is factory **default**.

Off

On

Drive supplies power to I/O pin 26 of SCSI bus; none to internal terminators. When drives have differential I/O circuits, a jumper on the right **TP** position may be needed to power external terminators (see system documentation). The "ND" drive has differential I/O circuits which have no terminator circuits on the drive.

On

On

Drive supplies terminator power to itself (internal connection) and to I/O pin 26 of SCSI bus. This is a legal jumper setting.

continued from previous page

TP Position A (Applies to "N" models only)

- On This horizontally positioned jumper across the two **TP** positions nearest PCB edge, connects terminator power from SCSI bus I/O pin 26 to the drive's internal terminators (for single-ended I/O only).
- Off See above explanations for **TP** jumpers.

J5

Jumper

Installation

A₀, A₁, A₂

Drive ID on SCSI Bus (J6 may be used instead, as J5 and J6 are in parallel. Use only one set for drive ID). The drive ID is binary coded positionwise i.e., jumper in position A₂ is drive ID 4, in position A₁ is ID 2, position A₀ is ID 1 and no jumpers is ID 0. **Default** is ID = 0.

J6

Jumper

Installation

A₂, A₁, A₀

Drive ID on SCSI bus. Either J5 or J6 (optional) may be used to select drive ID. Both should not be used at the same time, because at some future time when the ID is changed the user could fail to configure both J5 and J6 the same. **Default** is ID = 0.

LED

No jumper ever installed. These pins used to connect a cable for a remote **LED** indicator. Pin 3 (top, nearest HDA), the anode connection, connects in the drive to the +5V supply through a pull-up resistor. Pin 4 (bottom), the cathode connection connects in the drive to signal common through the emitter-collector junction of a transistor switch that controls the **LED** on/off condition.

10.2 Grounding

Signal ground (PCB) and HDA ground are connected together in the drive and cannot be separated by the user. The equipment in which the drive is mounted is connected directly to the HDA and PCB with no electrically isolating shock mounts. If it is desired for the system chassis to not be connected to the HDA/PCB ground, the systems integrator or user must provide a nonconductive (electrically isolating) method of mounting the drive in the host equipment.

11.0 Interface requirements

11.1 General description

This section partially describes the interface requirements as implemented on the drives. The major portion of the interface requirements/implementation is described in the Seagate SCSI Interface Product Manual, P/N 77738479. This section has tables that give the Hawk 2LP Family drives version of the SCSI implementation described in the 77738479 document.

11.2 SCSI interface messages supported

Table 11.2-1 following lists the messages supported by the SCSI-1, SCSI-2 and SCSI-3 modes of the Hawk 2LP Family drives.

Table 11.2-1. SCSI messages supported by Hawk 2LP family drives

Msg Code	Supported by:		Message Name
	SCSI-1	SCSI-2/3	
01h[1]	Y	Y	Extended Messages
06h	Y	Y	Abort
0Dh	Y	Y	Abort-tag
0Ch	Y	Y	Bus device reset
0Eh	Y	Y	Clear queue
00h	Y	Y	Command complete
12h	Y	Y	Continue I/O process
04h	Y	Y	Disconnect
80h-FFh	Y	Y	Identify
23h	N	N	Ignore wide residue (two bytes)
0Fh	N	N	Initiate recovery
05h	Y	Y	Initiator detected error
0Ah	N	N	Linked command complete [2]
0Bh	N	N	Linked command complete with flag [2]
09h	Y	Y	Message parity error
07h	Y	Y	Message reject
[1]	N	N	Modify data pointer
08h	Y	Y	No operation
			Queue tag messages (two bytes)
21h	Y	Y	Head of queue tag
22h	Y	Y	Ordered queue tag
20h	Y	Y	Simple queue tag
10h	N	N	Release recovery
03h	Y	Y	Restore pointers
02h	Y	Y	Save data pointer
[1]	Y	Y	Synchronous data transfer req.
13h	Y	Y	Target transfer disable
11h	N	N	Terminate I/O process
[1]	N	N	Wide data transfer request

Notes.

[1] Extended messages (see P/N 77738479 SCSI Interface Product Manual).

[2] Customer Unique.

11.3 SCSI interface commands supported

Table 11.3-1 following lists the SCSI interface commands that are supported in the SCSI-1, SCSI-2 and SCSI-3 modes of the drive. Hawk 2LP Family drives can be changed back and forth between SCSI-1 and SCSI-2/SCSI-3 modes using the Change Definition Command. OEM standard drives are shipped set to operate in SCSI-2/SCSI-3 mode.

Table 11.3-1. Commands supported by Hawk 2LP family drives

Com'd Code	Supported by:		Command Name	
	SCSI-1	SCSI-2/3		
00h	Y	Y	Test unit ready	
01h	Y	Y	Rezero unit	
03h	Y	Y	Request sense	
	Y	Y	Extended sense	
	Y	Y	Field pointer bytes	
	Y	Y	Actual retry count bytes	
	Y	Y	Deferred error supported	
04h	Y	Y	Format unit [1]	
	N	N	Block format	
	Y	Y	Bytes from index format	
	Y	Y	Physical sector format	
	N	N	DPRY bit supported	
07h	Y	Y	Reassign blocks	
08h	Y	Y	Read	
0Ah	Y	Y	Write	
0Bh	Y	Y	Seek	
12h	Y	Y	Inquiry	
	Y	Y	Vital product data page	
	Y	Y	Unit serial number page	
	Y	Y	Implemented operating def page	
	Y	Y	Firmware numbers page	
	Y	Y	Date code page	
	Y	Y	Jumper settings page	
	N	Y	Device Behavior page	
	15h	Y	Y	Mode select (same pages as mode Sense command, see below)
		Y	Y	Reserve
16h	Y	Y	3rd party reserve	
	N	N	Extent reservation	
	Y	Y	Release	
18h	N	N	Copy	
1Ah	Y	Y	Mode sense	
	Y	Y	Unit attention page (00h)	
	Y	Y	Byte 2 bit 4 (unit attn bit)	
	Y	Y	Byte 2 bit 5 (DEID bit)	
	Y	Y	Error recovery page (01h)	
	Y	Y	Disconnect/reconnect (02h)	
	Y	Y	Format page (03h)	
	Y	Y	Rigid disc drive geometry page (04h)	
	N	Y	Verify error recovery page (07h)	
	Y	Y	Caching parameters page (08h)	
	N	Y	Control mode page (0Ah)	
	N	Y	Notch and Partition Page (0C)	

[1] The drive can format to any even number of bytes per sector from 256 to 4096.

continued from previous page

Com'd' Code	Supported by:		Command Name
	SCSI-1	SCSI-2/3	
1Bh	Y	Y	Start unit/stop unit (spindle ceases rotating)
1Ch	Y	Y	Receive diagnostic results
	Y	Y	Supported diagnostics pages
	Y	Y	Translate page
1Dh	Y	Y	Send diagnostics page
	Y	Y	Supported diagnostics pages
	Y	Y	Translate page
25h	Y	Y	Read capacity
28h	Y	Y	Read extended
2Ah	Y	Y	Write extended
2Bh	Y	Y	Seek extended
2Eh	Y	Y	Write and verify
2Fh	Y	Y	Verify
30h	N	N	Search data high
31h	N	N	Search data equal
32h	N	N	Search data low
33h	N	N	Set limits
34h	N	N	Prefetch
35h	Y	Y	Synchronize cache
36h	N	N	Lock-unlock cache
37h	Y	Y	Read defect data
39h	N	N	Compare
3Ah	N	N	Copy and verify
3Bh	Y	Y	Write buffer
3Ch	Y	Y	Read buffer
3Eh	Y	Y	Read long
3Fh	Y	Y	Write long
40h	Y	Y	Change definition
41h	N	N	Write same
42-4Bh	N	N	Not used
4Ch	Y	Y	Log select
4Dh	Y	Y	Log sense
4E-54h	N	N	Not used
55h	Y	Y	Mode select (10)
56h	Y	Y	Reserve (10)
57h	Y	Y	Release (10)
58-59h	N	N	Not used
5Ah	Y	Y	Mode sense (10)
5B-5Fh	N	N	Not used
60-BFh	N	N	Not used
C0-DFh	N	N	Not used
E0-FFh	N	N	Not used

11.3.1 Inquiry data

11.3.1.1 Standard Inquiry data

Table 11.3.1-1 following lists the Standard Inquiry command data that the drive should return to the initiator per the format given in the SCSI-2 Interface Product Manual P/N 77738479, section 5.1.1.3.

Table 11.3.1-1. Hawk 2LP family drive Standard Inquiry data

Bytes	Data (HEX)	
0-15	00 00 ** *** 8F 00 00 12 53 45 41 47 41 54 45 20	VENDOR ID
16-31	53 54 [33][32][34][33][30][4E][20] 20 20 20 20 20 20 20	PRODUCT ID
32-47	R# R# R# R# S# S# S# S# S# S# S# S# 00 00 00 00	
48-63	00 00 00 00 00 00 00 00 00 00 00 00 00 00 00 00	
64-79	00 00 00 00 00 00 00 00 00 00 00 00 00 00 00 00	
80-95	00 00 00 00 00 00 00 00 00 00 00 00 00 00 00 00	
96-111	00 43 6F 70 79 72 69 67 68 74 20 28 63 29 20 31*	*COPYRIGHT
112-127	39* 39* 33* 20 53 65 61 67 61 74 65 20 41 6C 6C 20	NOTICE
128-143	72 69 67 68 74 73 20 72 65 73 65 72 76 65 64 20	
144-148	D# D# D# D#	

*Copyright Year - changes with actual year.

Notes.

- ** 01 means SCSI-1 implemented;
02 means SCSI-2/SCSI-3 implemented. Hawk 2LP Family drives can be changed between these two configurations. Default is 02.
- *** 01 means response data is in SCSI-1 format and has compatibility with Common Command Set data.
02 means response data is in SCSI-2/SCSI-3 format (some SCSI-3 features are also supported). The drive can be changed between these two configurations. Default is 02.
- R# Four ASCII digits representing the last four digits of the product Firmware Release number. This information is also given in the Vital Product data page C0h, together with servo RAM and ROM release numbers.
- S# Eight ASCII digits representing the eight digits of the product serial number.
- D# Four ASCII digits representing the firmware distribution diskette serial number.
- [] Bytes 18 through 24 will reflect model of drive. Shown here are hex values for Model ST32430N. Values for ST31230N are 33 31 32 33 30 4E 20.

For model ND byte 24 is 44 (D).

11.3.1.2 Inquiry Vital Product data

Instead of the standard Inquiry data shown in Table 11.3.1-1, the initiator can request several Vital Product Data pages by setting the Inquiry command EVPD bit to one. The SCSI, Version 2 Interface Product Manual P/N 77738479, section 5.1.1.3.1 lists the Vital Product Data pages supported and describes their formats. A separate Inquiry command must be sent to the drive for each Vital Product Data page the initiator wants the drive to send back.

11.3.2 Mode Sense data

The Mode Sense command provides a means for the drive to report its operating parameters to the initiator. The drive maintains four sets of Mode parameters, Default values, Saved values, Current values and Changeable values.

Default values are hard coded in the drive firmware that is stored in flash E-PROM nonvolatile memory on the drive PCB. Default values can be changed only by downloading a complete set of new firmware into the flash E-PROM. An initiator can request and receive from the drive a list of Default values and use those in a Mode Select command to set up new Current and Saved values.

Saved values are stored on the disk media using a Mode Select command. Only parameter values that are allowed to be changed can be changed by this method. See "Changeable values" defined below. Parameters in the Saved values list that are not changeable by the Mode Select command get their values from the Default values storage.

Current values are volatile values currently being used by the drive to control its operation. A Mode Select command can be used to change these values (only those that are changeable). Originally, they are installed from Saved or Default values after a power on reset, hard reset, or Bus Device Reset message.

Changeable values form a bit mask, stored in nonvolatile memory, that dictates which of the Current values and Saved values can be changed by a Mode Select command. A "one" allows a change to a corresponding bit; a "zero" allows no change. For example, in Table 11.3.2-1 refer to Mode page 01, in the first row entitled "CHG". These are hex numbers representing the changeable values for Mode page 01. Note in columns 1 and 2 (bytes 00 and 01), there is 00h, which indicates that in bytes 00 and 01 none of the bits are changeable. Note also that bytes 04, 05, 06 and 07 are not changeable, because those fields are all zeros. In bytes 02, hex value FF equates to the binary pattern 1111 1111. If there were a zero in any bit position in the field, it would mean that bit is not changeable. However, bits 7 - 0 are changeable, because those bits are all ones. In this particular case, it indicates 8 error recovery control bits are all changeable. FF in column 4 indicates all bits in byte 3 are changeable.

The Changeable values list can only be changed by downloading new firmware into the flash E-PROM.

On drives requiring unique Saved values, the required unique Saved values are stored into the Saved values storage location on the media prior to shipping the drive. Some drives may have unique firmware with unique Default values also.

On standard OEM drives the Saved values are taken from the Default values list and stored into the Saved values storage location on the media prior to shipping.

When a drive is powered up, it takes Saved values from the media and stores them to the Current values storage in volatile memory. It is not possible to change the Current values (or the saved values) with a Mode Select command before the drive is up to speed and is "ready." An attempt to do so results in a "Check Condition" status being returned.

Note.

Because there may be several different versions of drive control firmware in the total population of drives in the field, the Mode Sense values given in the following tables may not exactly match those of some drives.

11.4 SCSI bus conditions and miscellaneous features supported

Asynchronous SCSI bus conditions supported by the drive are listed in Table 11.4-1. These conditions cause the SCSI device to perform certain actions and can alter the phase sequence. Other miscellaneous operating features supported are also listed here.

Table 11.4-1. SCSI bus conditions and other misc. features

Condition/Feature Supported by:

SCSI-1	SCSI-2/SCSI-3	Conditions or Feature
Y	Y	Attention Condition
Y	Y	Reset Condition
Y	Y	Contingent Allegiance Condition
N	N	Asynchronous Event Notification
Y	Y	Arbitrating System
Y	Y	Disconnect/Reconnect
Y	Y	Asynchronous Data Transfer
Y	Y	Synchronous Data Transfer
N	N	Synchronized (locked) Spindle Operation
Y	Y	Differential Interface Circuits available
Y	Y	Segmented Caching
N	N	Zero Latency Read
Y	Y	Queue tagging (up to 64 Que tags supported)
Y	Y	Deferred Error Handling
Y	Y	Parameter Rounding
Y	Y	Reporting actual retry count in Extended Sense bytes 15, 16 and 17.
N	N	Adaptive Caching (available only on some drives)
N	N	SMP = 1 in Mode Select command needed to save RPL and Rotational Offset bytes (in Table 5.2.1-25 of Vol. II).
[1]	[1]	Flag and Link bits in Control Byte supported
Y	Y	Immediate status on Start/Stop command
Y	Y	Immediate status on Format unit command
N	N	Immediate status on Synchronize Cache command
Y	Y	Format progress indication
SCSI-1	SCSI-2/SCSI-3	Status Supported
Y	Y	Good
Y	Y	Check Condition
N	N	Condition Met/Good
Y	Y	Busy
[1]	[1]	Intermediate/Good
N	N	Intermediate/Condition Met/Good
Y	Y	Reservation Conflict
Y	Y	Queue Full

Notes.

[1] Option supported only if customer requests.

11.5 Synchronous data transfer

11.5.1 Synchronous data transfer periods supported

Table 11.5-1 and 11.5-2 list Synchronous Data transfer periods supported by the drive. The data transfer period to be used by the drive and the initiator is established by an exchange of messages during the Message Phase of operation. See the section on message protocol in the SCSI Interface manual*.

Table 11.5-1. Synchronous data transfer periods for drive

M (Decimal)	Transfer period (M times 4 nanoseconds)
25	100
31	124
37	150
50	200
62	250
75	300
87	350
100	400

11.5.2 REQ/ACK offset

The maximum value supported by the Hawk 2LP Family drives for REQ/ACK offset is 15 (0Fh).

11.6 Physical interface

Figure 11.6-1 shows the locations of the physical interface components for the N/ND drives. Shown are the locations of the D.C. power connector, the SCSI interface connector, the I/O line terminators, and the drive select and option select header.

Details of the physical, electrical and logical characteristics are given in paragraphs following, while the SCSI operational aspects of Seagate drive interfaces are given in the Seagate SCSI Interface Product Manual, P/N 77738479.

*SCSI Interface Product Manual, P/N 77738479

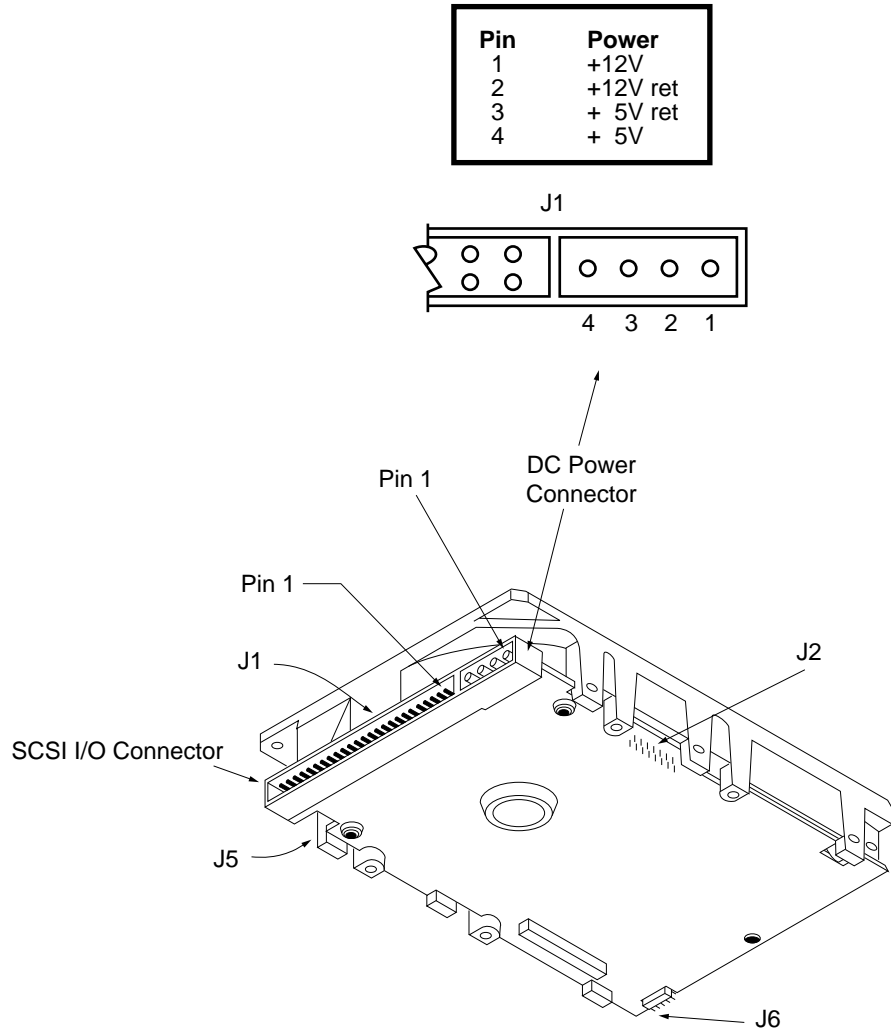

Figure 11.6-1. Physical interface

11.6.1 DC cable and connector

The drive receives DC power through a 4 pin connector (see Figure 11.6-1 for pin assignment) mounted at the rear of the main PCB. Recommended part numbers of the mating connector are listed below, but equivalent parts may be used (see Table 11.6-1).

Table 11.6.1-1. Mating connector parts

Type of Cable	Connector	Contacts (20-14 AWG)
14 AWG	MP 1-480424-0	AMP 60619-4 (Loose Piece) AMP 61117-4 (Strip)

11.6.2 Physical characteristics

This section defines the connectors, cables, signals, terminators and bus timing needed to implement SCSI.

11.6.2.1 Physical description

The drives may be daisy-chained together or with other compatible SCSI devices using a common cable. Both ends of the cable must be terminated. The "N" model drive implements single ended drivers and receivers. The "ND" model drive implements differential drivers and receivers. All signals are common between all SCSI devices. The drive may be daisy-chained only with SCSI devices having the same type drivers and receivers. Devices having single ended interface circuits cannot be on the same daisy-chain with devices having differential interface circuit. A maximum of 8 SCSI devices (including the Host) may be daisy-chained together. The SCSI Devices at both ends of the daisy-chain are to be terminated. Intermediate SCSI devices shall not be terminated (see Figure 11.6.3-2). Remove the terminator enable jumper **TE** on J2 select header ("N" models), or the external terminators ("ND" models), not the terminator power source selector jumper **TP** (Figure 10.1-1).

11.6.2.2 Cable requirements

The maximum total cable length for use with drives having single ended I/O driver and receiver circuits shall be 6 metres (19.7 ft.) when operating at line data transfer rates of 5 Mbytes/sec or less, and 3 metres (9.85 ft.) when operating at transfer rates greater than 5 Mbytes/sec (FAST SCSI). A stub length of no more than 0.1 metre (0.33 ft.) is allowed off the mainline interconnection with any connected equipment. An ideal impedance match with cable terminators implies a cable characteristic impedance of 132 ohms. Single ended I/O cable pin assignments are shown in Table 11.6.3-1.

11.6.2.3 General cable characteristics

In general, cables having the characteristic impedance's given in 11.6.2.2 are not available; however, impedance's that are somewhat lower are satisfactory. A characteristic impedance of 100 ohm $\pm 10\%$ is recommended for unshielded flat or twisted pair ribbon cable. However, most available cables have a somewhat lower characteristic impedance. To minimize discontinuances and signal reflections, cables of different impedance's should not be used in the same bus. Implementations may require trade-offs in shielding effectiveness, cable length, the number of loads, transfer rates, and cost to achieve satisfactory system operation. If shielded and unshielded cables are mixed within the same SCSI bus, the effect of impedance mismatch must be carefully considered. Proper impedance matching is especially important in order to maintain adequate margin at FAST SCSI transfer rates.

Only nonshielded cable connectors are applicable. A 50 conductor flat cable or 25 twisted pair cable shall be used. A minimum conductor size of 28 AWG should be used to minimize noise effects.

Suggested nonshielded flat cable part numbers are:

Flat cable - 35M-3365-50 Twisted pair - Spectra Twist in flat 455-248-50

11.6.3 Mating connector requirements

11.6.3.1 Mating connectors for models N/ND

The nonshielded cable connector shall be a 50 conductor connector consisting of two rows of 25 male contacts with adjacent contacts 100 mils apart.

Recommended mating flat cable connector part numbers are:

Closed end (for cable ends)*	3M-3425-7000	W/O Strain Relief, No Center Key
	3M-3425-7050	With Strain Relief, No Center Key
	Dupont-66900-290	With Strain Relief, With Center Key
Open end (In daisy-chain)	3M-3425-6000	W/O Strain Relief, No Center Key
	3M-3425-6050	With Strain Relief, No Center Key
	Dupont-66900-250	With Strain Relief, With Center Key

*See Figure 11.6.3-2.

The drive device connector is a nonshielded 50 conductor connector consisting of two rows of 25 female pins with adjacent pins 100 mils apart. The connector is keyed (see Figure 11.6.3-1).

11.6.3.2 Jumper plug part number for J2

Option select header connector J2 on the PCB (see Figure 10.1-1) uses an unusual type of jumper plug so its part number is given here for reference. Suggested part no. for J2 jumper:

Molex 52747-0211 (Seagate P/N 77679052)

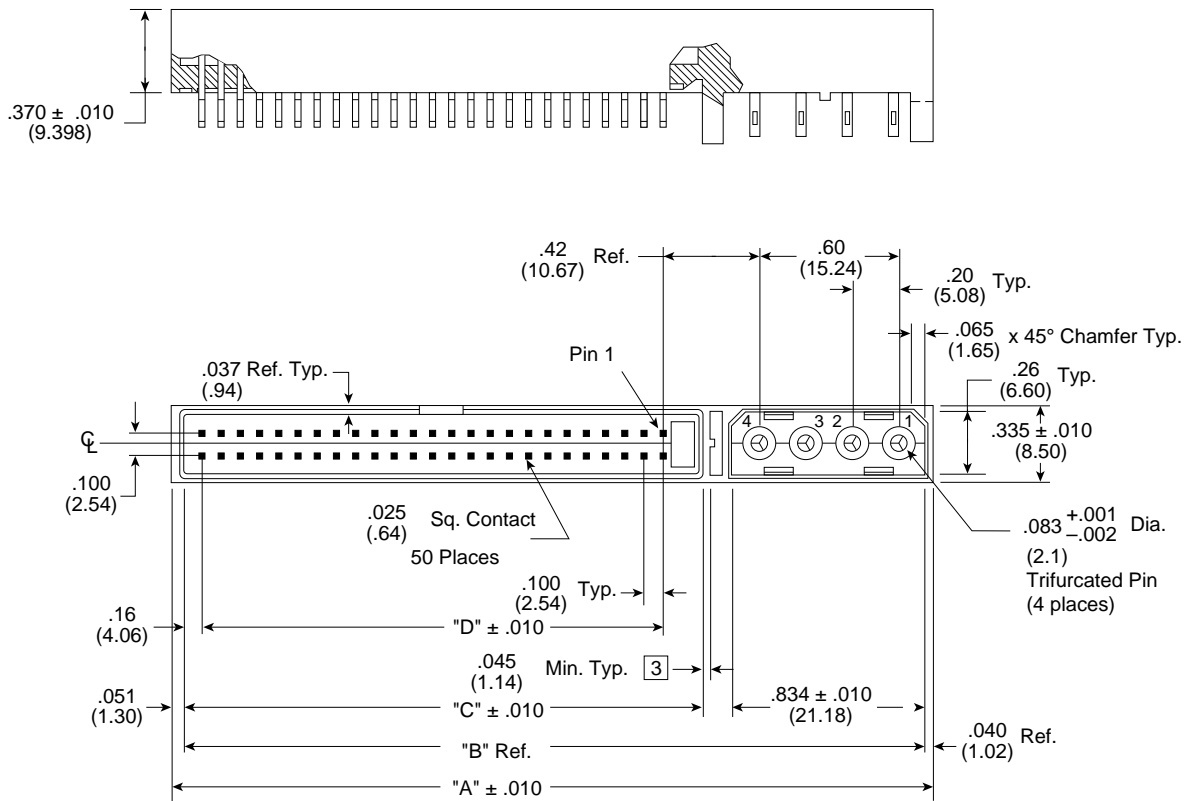

No. Pos.	"A"	"B"	"C"	"D"
50	3.767 (95.68)	3.697 (93.90)	2.720 (69.09)	2.400 (60.96)

Figure 11.6.3-1. Nonshielded 50 pin SCSI device connector

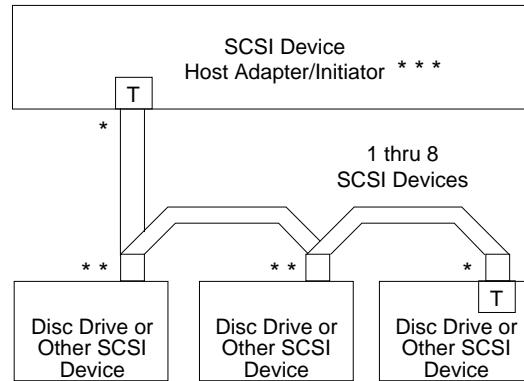

VIEW B - T indicates termination required

Total interface cable length must not exceed that specified in paragraph 11.6.2.2. (including host adapter/initiator).

- * Closed end type connector used.
- ** Open end type (in-line application) connector used.
- *** Host need not be on the end of the daisy-chain. Another device can be on the end with the terminator, the host having no terminator.

Figure 11.6.3-2. Interface cabling

Table 11.6.3-1a. Single ended, 50 pin cable pin assignments (Nonshielded connector) (N models)

Signal	Pin Number	Signal	Pin Number
-DB (0)	2	GROUND	30
-DB (1)	4	-ATN	32
-DB (2)	6	GROUND	34
-DB (3)	8	-BSY	36
-DB (4)	10	-ACK	38
-DB (5)	12	-RST	40
-DB (6)	14	-MSG	42
-DB (7)	16	-SEL	44
-DB (P)	18	-C/D	46
GROUND	20	-REQ	48
GROUND	22	-I/O	50
GROUND	24		
TERMPWR	26		
GROUND	28		

Notes.

1. All odd pins except pin 25 are connected to ground. Pin 25 is left open.

Caution

Pin 25 must not be connected to ground at the HOST end or the drive end of the cable. If the I/O connector should accidentally be plugged upside down, terminator power on pin 26 will be shorted to ground.

2. The minus sign next to the signals indicates asserted state is the low voltage of the two levels used for logic signals.

Table 11.6.3-1b. Differential cable pin assignments (Nonshielded connector) (ND models)

+Signal Name*	Pin Number		-Signal Name*
SHIELD GND	1	2	GROUND
+DB(0)	3	4	-DB(0)
+DB(1)	5	6	-DB(1)
+DB(2)	7	8	-DB(2)
+DB(3)	9	10	-DB(3)
+DB(4)	11	12	-DB(4)
+DB(5)	13	14	-DB(5)
+DB(6)	15	16	-DB(6)
+DB(7)	17	18	-DB(7)
+DB(P)	19	20	-DB(P)
DIFFSENS	21	22	GROUND
GROUND	23	24	GROUND
TERMPWR	25	26	TERMPWR
GROUND	27	28	GROUND
+ATN	29	30	-ATN
GROUND	31	32	GROUND
+BSY	33	34	-BSY
+ACK	35	36	-ACK
+RST	37	38	-RST
+MSG	39	40	-MSG
+SEL	41	42	-SEL
+C/D	43	44	-C/D
+REQ	45	46	-REQ
+I/O	47	48	-I/O
+GROUND	49	50	GROUND

* See Paragraph 11.6.4.2 for detailed electrical characteristics of these differential signals.

11.6.4 Electrical description

Model "N" drives use single ended interface signals. These signals must be terminated with 110 ohm active termination circuits at each end of the total cable. On "N" models, the terminators are enabled (or disabled) by installing (or removing) jumper plug **TE**. See Figure 10.1-1. Single Ended circuits use open collector or three state drivers. See Figure 11.6.4-1 and 11.6-1. The model NC has no provisions for terminators on the drive.

The "ND" model drives use differential interface signals and each of these must be terminated at each end of the total cable with 330 ohms to +5 V and 330 ohms to ground with 150 ohms between each differential pair. All I/O circuits are open collector, three state drivers. See Figure 11.6.4-2 for circuit drawing. Differential I/O drives are shipped without terminators. These drives have no provisions for adding terminator sockets on the PCB. On these drives some method of external termination must be provided by the drive user, systems integrator or host equipment manufacturer.

11.6.4.1 Single ended drivers/receivers

For "N" models which use single ended drivers and receivers, typical circuits are shown in Figure 11.6.4-1. Terminator circuits (Note [1]) are to be enabled (model N) only when the disc drive is first or last in the daisy-chain.

Transmitter Characteristics

Single ended drives use an ANSI SCSI compatible open collector single ended driver. This driver is capable of sinking a current of 48 mA with a low level output voltage of 0.4 volt.

Receiver Characteristics

Single ended drives use an ANSI SCSI single ended receiver with hysteresis gate or equivalent as a line receiver.

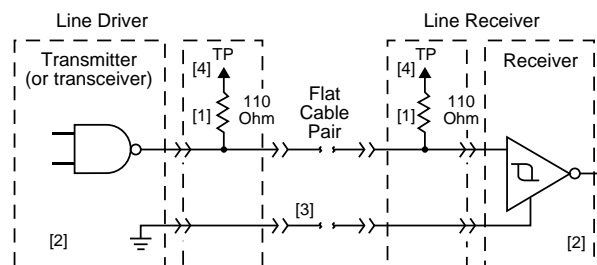

[1] Part of active terminator circuits. Non-removable LSI terminators, enabled in the drive (model "N" only) with jumper plug **TE** when it is first or last in the daisy-chain. Interface signals levels and logical sense at the drive I/O connector are defined as follows:

Logic Level	Driver Output	Receiver Input
NEGATED (0)	≥ 2.5 V: < 5.25 V	≥ 2.0 V: ≤ 5.25 V
ASSERTED (1)	≤ 0.4 V: > 0.0 V	≤ 0.8 V: ≥ 0.0 V

The difference in the voltages between input and output signals is due to the losses in the cable.

[2] ANSI SCSI compatible circuits

[3] Total interface cable length should not exceed that specified in Section 11.6.2.2.1.

[4] Source of drive terminator power is an active circuit which has an input source voltage selected by jumper plug **TP**. See Figure 10.1-1. Applies to model "N" only.

Figure 11.6.4-1. Single ended transmitters and receivers

11.6.4.2 Differential drivers/receivers

Differential drivers and receivers are used by the "ND" models. Typical circuits are shown in Figure 11.6.4-2. The drive has no provisions for terminator circuits on differential I/O drives.

Differential Signals

All differential interface signals consist of two lines denoted +SIGNAL and -SIGNAL. A signal is true when +SIGNAL is more positive than -SIGNAL, and a signal is false when -SIGNAL is more positive than +SIGNAL. All assigned signals shall be terminated at each end of the cable as shown in Figure 11.6.4-2. Drive user or systems integrator must provide some external means of termination.

Output Characteristics

Each signal driven by differential interface drives shall have the following output characteristics when measured at the disc drive SCSI connector:

Low-level output voltage* = 2.0 V maximum at Low-level output current = 55 milliamps.

High-level output voltage* = 3.0 V minimum at High-level output current = -55 milliamps

Differential voltage = 1.0 V minimum with common-mode voltage ranges from -7 V dc to +12 V dc.

* These voltages shall be measured between the output terminal and the SCSI device's logic ground reference.

The output characteristics shall additionally conform to EIA RS-485-1983.

Input Characteristics

Each signal received by differential interface drives shall have the following input characteristics when measured at the disc drive SCSI connector:

Input current on either input = +2.0 milliamps maximum (includes both receivers and passive drivers).

This requirement shall be met with the input voltage varying between -7 V dc and +12 V dc, with power on or off, and with the hysteresis equaling 35 mv, minimum.

The input characteristics shall additionally conform to EIA RS-485-1983.

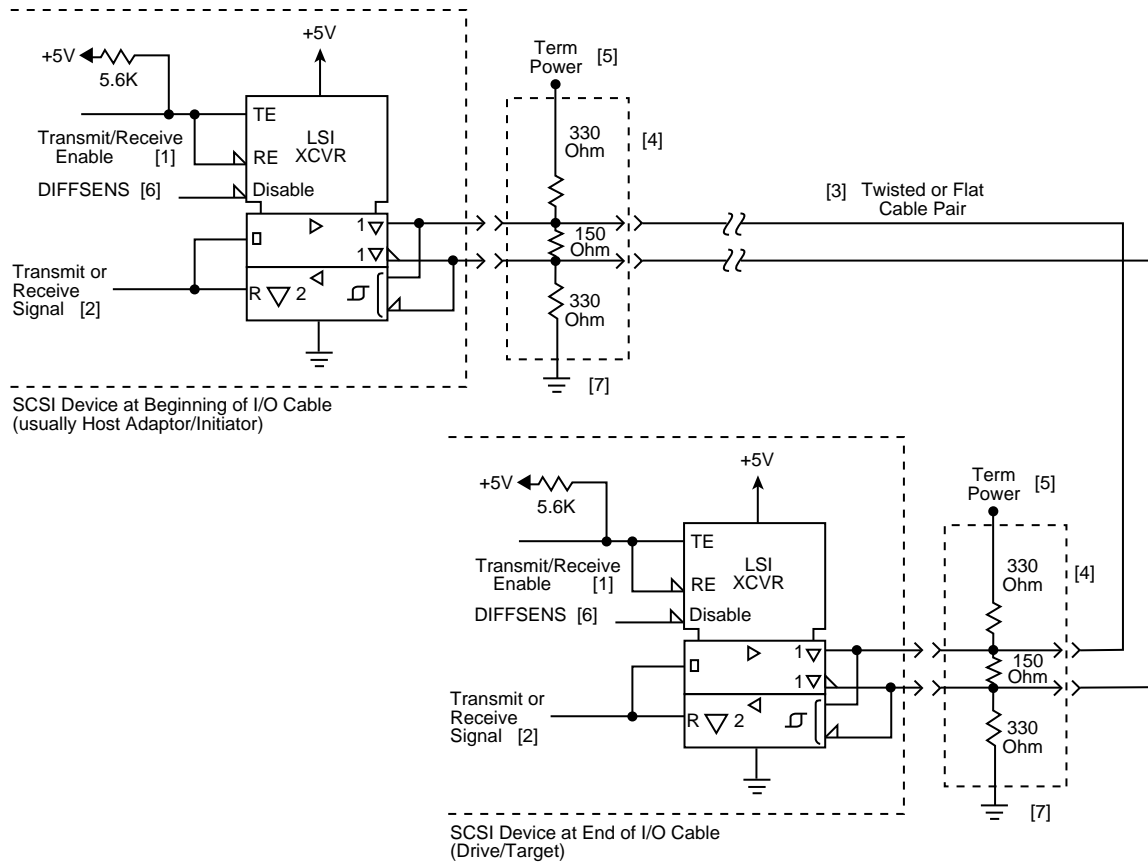
**Notes.**

- [1] Positive Logic Enables Transmitter (+5 V = Asserted)
Negative Logic Enables Receivers (0 V = Asserted)
- [2] Negative Logic Signal (0 V = Asserted)
- [3] Total interface cable length should not exceed value given in paragraph 11.6.2.2 from first SCSI device at beginning to end of daisy-chain. See section 11.6.4.2 for signal characteristics.
- [4] I/O Line terminators. If SCSI device is a Seagate disc drive, terminators and a place to plug them in must be provided external to the drive by user, systems integrator or host equipment manufacturer where needed. The drive has no terminators and there are no provisions on the drive for terminator installation.
- [5] Arrangements for connecting terminator power to the terminators must be made by the systems designer. As a help, drive +5 V power is made available on SCSI bus pin 26 ("N" and "ND" models) for powering external terminators if the drive option select header jumper **TP** (Figure 10.1-1) is installed in rightmost position "**TP**".
- [6] SCSI I/O line (pin 21) disables I/O circuits if single-ended cable plugged in or cable plugged in upside down.
- [7] SCSI I/O cable ground. See Table 11.6.3-1b.

Figure 11.6.4-2. Typical differential I/O line transmitter/receiver and external terminators

11.6.4.3 Terminator requirements

Internal disc drive I/O termination (provided only in single ended I/O model drives) consists of active circuits in an LSI module that is permanently mounted on the PCB. All single initiator/single target (nondaisychain) applications require that the Initiator and disc drive be terminated. Daisychain applications require that only the units at each end of the daisy-chain be terminated. All other peripherals on the chain must not be terminated. (See Figure 11.6.3-2).

Note. Remove drive terminator enabling jumper **TE** (see Figure 10.1-1) where terminators are not required. Removal of terminator power source selection jumper **TP** (see Figure 10.1-1) does not disconnect the terminator resistors from the circuit.

It is highly recommended that ANSI SCSI-2 Standard's Alternative 2 termination (active termination) be used for applications with single-ended ("N" models), especially if the bus will be operated at transfer rates above 5 Mbytes/sec. The "N" model provides on-board active termination that can be disabled by removal of the enable jumper **TE** (see Figure 10.1-1).

Note. ACTIVE TERMINATORS ARE HIGHLY RECOMMENDED FOR USE IN THE DAISYCHAIN AS DESCRIBED ABOVE. ACTIVE AND PASSIVE TERMINATORS SHOULD NOT BE MIXED ON THE SAME SCSI BUS.

Differential I/O "ND" models do not have terminators on the PCB. The user, systems integrator or host equipment manufacturer must provide a terminator arrangement external to the drive.

11.6.4.4 Terminator power

The drive may be configured to accept terminator power from pin 26 of the SCSI Bus, to supply power to the SCSI bus or to provide terminator power for internal termination circuits from the drive power connector. See Figures 10.1-1 and 11.6-1. The drive can provide power both to its own terminators and to the SCSI Bus terminator power line (Pin 26) if both "**TP**" jumpers are on.

SCSI devices providing terminator power (TERMPWR)* shall have the following characteristics:

V TERM = 4.50 V to 5.25 V
800 mA min source drive capability
1.0 A maximum

*See Figure 10.1-1 for configuration details.

11.7 Disc drive SCSI timing

Table 11.7-1. Disc drive SCSI timing

Description	Waveform Symbol [1]	Waveform Table [1]	Typical
Target Select Time (no Arbitration)	T00	N/A	<1 μ s
Target Select Time (with Arbitration)	T01	4.5-1,2	1.74 μ s
Target Select to Command	T02	4.5-1	3.87 μ s
Target Select to MSG Out	T03	4.5-2	1.86 μ s
Identify MSG to Command	T04	4.5-3	3.56 μ s
Command to Status	T05	4.5-5	Command Dependent
Command to Data (para. In)	T06	4.5-9	Command Dependent
Command to Data (para. Out)	T07	4.5-10	Command Dependent
Command to Data (Write to Data Buffer)	T08	4.5-10	Command Dependent
Command to Disconnect MSG	T09	4.5-6	Command Dependent
Disconnect MSG to Bus Free	T10	4.5-6,14	0.52 μ s
Disconnect to Arbitration (for Reselect)	T11	4.5-6	Command Dependent
This measures disconnected CMD overhead.			
Target win Arbitration (for Reselect)	T12	4.5-7	
Arbitration to Reselect	T13	4.5-7	
Reselect to Identify MSG In	T14	4.5-7	
Reselect Identify MSG to Status	T15	4.5-8	Command Dependent
Reselect Identify MSG to Data (media)	T16	4.5-11	Command Dependent
Data to Status	T17	4.5-15	Command Dependent
Status to Command Complete MSG	T18	4.5-5,8,15	
Command Complete MSG to Bus Free	T19	4.5-5,8,15	
Data to Save Data Pointer MSG	T20	4.5-14	
Save Data Pointer MSG to Disconnect MSG	T21	4.5-14	
Command Byte Transfer	T22	4.5-4	
Next Command Byte Access		4.5-4	
Next CDB Byte Access (Byte 2 of 6)	T23.6.2	4.5-4	0.64 μ s
Next CDB Byte Access (Byte 3 of 6)	T23.6.3	4.5-4	0.12 μ s
Next CDB Byte Access (Byte 4 of 6)	T23.6.4	4.5-4	0.11 μ s
Next CDB Byte Access (Byte 5 of 6)	T23.6.5	4.5-4	0.12 μ s
Next CDB Byte Access (Byte 6 of 6)	T23.6.6	4.5-4	0.12 μ s

continued from previous page

Description	Symbol [1]	Waveform Table [1]	Waveform Typical
Asynchronous Data Transfer Characteristics: (continued)			
Next CDB Byte Access (Byte 2 of 10)	T23.10.2	4.5-4	0.65 μ s
Next CDB Byte Access (Byte 3 of 10)	T23.10.3	4.5-4	0.11 μ s
Next CDB Byte Access (Byte 4 of 10)	T23.10.4	4.5-4	0.12 μ s
Next CDB Byte Access (Byte 5 of 10)	T23.10.5	4.5-4	0.11 μ s
Next CDB Byte Access (Byte 6 of 10)	T23.10.6	4.5-4	0.11 μ s
Next CDB Byte Access (Byte 7 of 10)	T23.10.7	4.5-4	0.13 μ s
Next CDB Byte Access (Byte 8 of 10)	T23.10.8	4.5-4	0.12 μ s
Next CDB Byte Access (Byte 9 of 10)	T23.10.9	4.5-4	0.12 μ s
Next CDB Byte Access (Byte 10 of 10)	T23.10.10	4.5-4	0.12 μ s
Data In Byte Transfer (parameter)	T24	4.5-12	
Data Out Byte Transfer (parameter)	T25	4.5-13	
Next Data In Byte Access (parameter)	T26	4.5-12	0.10 μ s
Next Data Out Byte Access (parameter)	T27	4.5-13	0.10 μ s
Data In Byte Transfer (media) [2]	T28	4.5-12	0.05 μ
Data Out Byte Transfer (media) [2]	T29	4.5-13	0.05 μ
Next Data In Byte access (media) [2]	T30	4.5-12	0.10 μ s
Next Data Out Byte access (media) [2]	T31	4.5-13	0.10 μ s
MSG IN Byte Transfer	T32	4.5-5,7 4.5-8,14,15	
MSG OUT Byte Transfer	T33	4.5-2	
STATUS Byte Transfer	T34	4.5-5,8 4.5-15	
Synchronous Data Transfer Characteristics:			
Request Signal Transfer Period [3]	-	-	various

Notes.

[1] See SCSI-2 Interface Manual P/N 77738479 (called Volume 2), section 4.5

[2] Maximum SCSI asynchronous interface transfer rate is given in section 5.3.

[3] Synchronous Transfer Period is determined by negotiations between an Initiator and a Drive. The Drive is capable of setting periods as given in section 11.5. See also sections 3.1.5.2 and 3.5.3.2 of the SCSI-2 Interface Product Manual (P/N 77738479) for a description of synchronous data transfer operation.

General timing diagrams for SCSI interface operation are shown in the SCSI-2 Interface Product Manual P/N 77738479, Section 4.5. The specific timing values that apply to this drive are listed in Table 11.7-1.

12.0 Options

All options are incorporated or packaged at the manufacturing facility.

12.1 Front panel

The normal front panel available is black plastic. Other panel colors may be special ordered. Each panel has a single rectangular green rectangular LED indicator lens which, when glowing, indicates the drive is selected.

12.2 Single unit shipping pack

The drive is normally shipped in bulk packaging to provide maximum protection against transit damage. Units shipped individually require additional protection as provided by the single unit shipping pack. Users planning single unit distribution should specify this option.

12.3 Installation Guide

The Installation Guide (P/N 77767475) is usually included with each drive shipped, but extra copies may be ordered. The Installation Guide provides basic information on the care and handling of Winchester disc peripherals in general. Some information needed when installing the drive is included to assist individuals not familiar with the product. It also includes basic information to assist in obtaining service for the drive.

13.0 Accessories

All accessories are designed for implementation by the customer.

13.1 Front panel kit

Same as 12.1 but includes all mounting hardware to support field installation.

13.2 Additional Installation Guide copies

The Installation Guide (P/N 77767475) is usually included with each drive shipped, but extra copies may be ordered.

14.0 Technical support services

Seagate Technology provides technical support literature and diagnostic utilities to Authorized Distributors. Please contact your dealer for technical support and installation troubleshooting. Product Technical Support is available for all Seagate products by calling the SeaFAX™, SeaFone™, SeaTDD™ or SeaBOARD™ services. These are toll calls.

SeaFAX number: United States 408/438-2620 England 44-62-847-7080

You can use a touch-tone telephone to access Seagate's automated FAX delivery system and select technical support information by return FAX. This service is available 24 hours a day, 7 days a week.

SeaFone telephone number: 408/438-8222

The enhanced phone system provides recorded technical information on selected Seagate products while you are on hold. Technical support specialists are available to answer questions from 8:00 AM to 5:00 PM PST, Monday through Friday. Recordings are accessible 24 hours a day, 7 days a week.

SeaTDD telephone number: 408/438-5382

TDD is a Telecommunication Device for the Deaf where two people can communicate using a keyboard that is connected to the phone line. A TDD device is required to access this service. This service is available from 8:00 AM to 5:00 PM PST, Monday through Friday.

SeaBOARD service:

The Seagate Technical Support Bulletin Board System (BBS) is available 24 hours a day, 7 days a week. A modem is required to access this service. (300–9600 baud, 8-N-1). This is a toll call.

With this service you can access:

- Specifications and jumper configurations for all Seagate products.
- Reprints of Seagate documentation.
- A directory of information and helpful utilities that you can download to your own computer.

BBS Location	Modem Number
USA, Mexico, Latin America	408-438-8771
Canada	416/856-5581
England	44-62-847-8011
France	33-1-40-67-1034
Germany	49-89-140-9331
Singapore	65-292-6973
Australia	61-2-756-2359
Korea	82-2-556-7294



Seagate Technology, Inc.
920 Disc Drive, Scotts Valley, California 95066-4544, USA

Publication Number: 77767471, Revision F

Printed in USA